

SAEINDIA
Society of Automotive Engineers INDIA

BAJA SAEINDIA 2026



Collegiate Design Series **BAJA SAEINDIA® Rules**

Applicable for hCNG BAJA

Draft 00



Foreword

Welcome to BAJA SAEINDIA 2026

The BAJA SAEINDIA® Rulebook Committee has come up with a new Rulebook for **hBAJA** for the **2026 season**. BAJA SAEINDIA has introduced a new event from the 2024 season which will include building a hydrogen (hCNG) powered vehicle capable of being driven in all terrain conditions in line with the National Green Hydrogen Mission adopted by Ministry of New & Renewable Energy (MNRE) as on January 2023. This competition will witness the teams implementing phase wise use hydrogen as potential power source for driving the ATV. The event aims to upgrade the level of BAJA SAEINDIA competition in line with the new advancements in the field of vehicle technologies worldwide, with specific focus on hydrogen vehicles. This competition shall open new avenues of innovation and learning to the teams.

Taking the next step forward, teams are expected to use **hCNG (5%-18% H₂)** for 2026 season, then subsequently move to hydrogen. The vision of the event is to Challenge engineering students to develop and demonstrate initially CNG, then HCNG with **5%-18% Hydrogen** & finally full Hydrogen engine BAJA Buggy. The technical goal of the competition is to develop IC engine vehicle with 0 to 100% Hydrogen transitioned gradually, with an aim towards safety & sustainability with zero Carbon Emission.

Thorough and repeated reading of the rulebook is strongly recommended!

Wishing all the team's good luck for an exciting BAJA SAEINDIA® season ahead.

Table of Contents

Contents

Foreword.....	3
Table of Contents	4
PART A: ADMINISTRATIVE REGULATIONS	7
ARTICLE A.1: BAJA SAE OVERVIEW	7
ARTICLE A.2: COMPETITION INFORMATION	8
ARTICLE A.3: BAJA SAEINDIA® RULES AND ORGANIZER AUTHORITY	9
ARTICLE A.4: PARTICIPATION REQUIREMENTS.....	13
ARTICLE A.5: VEHICLE ELIGIBILITY.....	15
ARTICLE A.6: REGISTRATION	16
ARTICLE A.7: REQUIRED EVENT SUBMISSIONS	21
PART B: TECHNICAL REQUIRMENTS.....	23
ARTICLE B.1: GENERAL DESIGN REQUIREMENTS	23
ARTICLE B.2: ENGINE (hBAJA Only)	24
ARTICLE B.3: hCNG INJECTION KIT.....	43
ARTICLE B.4: hCNG Vehicle Packaging & Overall Integration	48
ARTICLE B.5: hCNG CYLINDER.....	63
ARTICLE B.6: Safety & Homologation Requirement–	63
ARTICLE B.7: hCNG Refilling:.....	64
ARTICLE B.3: ROLL CAGE	65
ARTICLE B.4: DRIVER RESTRAINT.....	49
ARTICLE B.5: DRIVER EQUIPMENT	60
ARTICLE B.6: FUEL (hCNG Gas Layout) SYSTEM & VEHICLE INTERFACE COMPONENTS.....	73
ARTICLE B.7: VEHICLE CONTROLS	74
ARTICLE B.8: COCKPIT	77
ARTICLE B.9: POWERTRAIN GUARDS.....	80
ARTICLE B.10: ELECTRICAL SYSTEM.....	86
ARTICLE B.11: TOW POINTS.....	91
ARTICLE B.12: FASTENERS	94
ARTICLE B.13: VEHICLE IDENTIFICATION AND MARKINGS	95
ARTICLE B.14: ERGONOMIC REQUIREMENTS FOR DRIVER SAFETY.....	94
PART C: Preliminary Round - 40 Points + 10 Points	96
PART D: STATIC EVENTS – 225 POINTS	97
ARTICLE D.1: SCORING.....	97
ARTICLE D.2: ENGINEERING DESIGN EVENT - 100 Points.....	97
ARTICLE D.3: COST EVENT - 50 Points.....	98
ARTICLE D.4: SALES PRESENTATION EVENT - 50 Points	98
ARTICLE D.5: SUSTAINABILITY EVENT - 25 POINTS	99
ARTICLE D.6: ENGINE SIMULATION	100
ARTICLE D.7: INNOVATION EVENT – NA POINTS	101
ARTICLE D.8: TIE BREAKERS.....	102
PART E: TECHNICAL EVALUATION	102
E.1 Technical Evaluation - Pass/Fail	102
E.2 Technical Evaluation Procedure	102
PART F: VIRTUAL DYNAMIC EVENT- 75 POINTS	105
ARTICLE F.1:OVERVIEW	105
ARTICLE F.2:OBJECTIVE	105
ARTICLE F.3:EVENT CONDUCT.....	105
PART G: DYNAMIC EVENTS – 675 POINTS.....	106

ARTICLE G.1: SCORING SUMMARY	106
ARTICLE G.2: PRACTICE	106
ARTICLE G.3: ACCELERATION	106
ARTICLE G.4: MANEUVERABILITY	107
G.4.1 Objective.....	107
G.4.2 Course.....	107
G.4.3 Procedure	108
G.4.4 Signals and Signage	108
G.4.5 Penalties	108
G.4.6 Scoring.....	108
ARTICLE G.5: EFFICIENCY EVENT.....	109
ARTICLE G.5.1: VALIDATION EVENT	109
ARTICLE G.6: ENDURANCE PERFORMANCE.....	109
ARTICLE G.7: GENERAL EVENT PROCEDURES AND REGULATIONS.....	115
PART H: APPENDICES.....	124
ARTICLE H.1: OVERALL EVENT SCORING SUMMARY	124
ARTICLE H.2: SAE TECHNICAL STANDARDS	125
ARTICLE H.3: OFFICIAL SOCIAL MEDIA HANDLES.....	126
ARTICLE H.4: LIST OF ABBREVIATIONS.....	127

Revision History

Date	Revision	Description	Author
29/06/2025	00	1 st Release – Draft copy	BAJA Tech Team

 *Read all Rules thoroughly!*

 *Please be sure to refer to the Baja SAEINDIA Website (<http://www.bajasaeindiaforum.com>) for all updates.*

Using this Document

 **Important Notes.**

 *Additional information and warnings.*

 *Reference to another article in this document.*

DRAFT

PART A: ADMINISTRATIVE REGULATIONS

ARTICLE A.1: BAJA SAE OVERVIEW

A.1.1 Program History

The BAJA SAE competition series originated at the University of South Carolina in 1976, under the direction of Dr. John F. Stevens. Since that time, the BAJA SAE Series has grown to become a premier engineering design series for university teams.

A.1.2 Collegiate Design Series Objective

SAE International's Collegiate Design Series (CDS) programs prepare undergraduate and graduate engineering students in a variety of disciplines for future employment in mobility-related industries by challenging them with a real-world, engineering application.

Through the Engineering Design Process, experiences may include, but are not limited to:

- Project management, budgeting, communication, and resource management skills.
- Team collaboration.
- Applying industry rules and regulations.
- Design, build, and test the performance of a real vehicle.
- Compete with other students from around the globe.
- Develop and prepare technical documentation.

Students also gain valuable exposure to and engagement with industry professionals to enhance 21st-century learning skills, build their network, and help prepare them for the workforce after graduation.

A.1.3 BAJA SAEINDIA® Program Objective

BAJA SAEINDIA® is an intercollegiate engineering design competition for undergraduate engineering students. The objective of the competition is to simulate real-world engineering design projects and their related challenges. Each team is competing to have its design accepted for manufacture by a fictitious firm. The students must function as a team to design, engineer, build, test, promote and compete with a vehicle within the limits of the rules. They must also generate financial support for their project and manage their educational priorities.

A.1.4 Design Subject

Each team's goal is to design and build a single-seat, all-terrain, sporting vehicle whose driver is contained within the structure of the vehicle. The vehicle is to be a prototype for a reliable, maintainable, ergonomic, and economical production vehicle that serves a recreational user market sized at approximately 4000 units per year. The vehicle should aspire to market-leading performance in terms of speed, handling, ride, and ruggedness over rough terrain and off-road conditions. The performance will be measured by success in the dynamic events which are described in the BAJA SAEINDIA® Rules and are subject to event-site weather and course conditions.

For the 2026 competition, the hBAJA teams have an option to incorporate 4WD/AWD or 2WD in their design. However, there will be no bonus points for opting 4WD/AWD. Demonstration of 4WD/AWD in working conditions is a must.

ARTICLE A.2: COMPETITION INFORMATION

A.2.1 Competitions

SAE International will host up to three competitions within the United States and Canada in a given competition year. Locations will change yearly and are dependent on local support of SAE Sections, Universities, and Sponsor Companies.

Competitions outside the US and Canada include:

- BAJA SAE Brazil – hosted by SAE Brazil
- BAJA SAE Korea – hosted by Yeungnam University
- BAJA SAE South Africa – Sponsored by Sasol and hosted by the Gerotek Test Facility
- BAJA SAE Mexico – hosted by SAE Mexico
- BAJA SAEINDIA – Up to Three Event locations - Sponsored by SAEINDIA

A.2.1.1 BAJA SAEINDIA® Competition

Started in 2007, BAJA SAEINDIA is a premier engineering competition organized by the Society of Automotive Engineers India (SAEINDIA), where university students design, build, and compete with small, off-road vehicles. The event aims to simulate real-world engineering design projects and their related challenges, providing participants with practical engineering experience.

BAJA SAEINDIA® is conducted for four different categories -

1. **mBAJA (IC Engine Vehicle)** - Students are required to design and fabricate a single seater All-Terrain Vehicle within the boundaries of the rulebook, propelled by an IC engine. This was the very first category of BAJA SAEINDIA and has been in place since inception.
2. **eBAJA (Battery Operated Vehicle)** - Started in 2015, with the vision of Dr. APJ Abdul Kalam to upskill engineering students for the upcoming challenges in mobility, the eBAJA category requires the students to build a battery operated, electric motor propelled single seater All-Terrain Vehicle and take part in various BAJA SAEINDIA events similar to the mBAJA category.
3. **hBAJA (hCNG Injected Engine Vehicle)** - The newest addition to BAJA SAEINDIA, this category aims to impart the knowledge of alternative fuels particularly towards Hydrogen powered IC Engines. It has begun with CNG powered IC engines, and will see the addition of Hydrogen in phases in the future.
4. **aBAJA (Autonomous Vehicle)** - One of the newest categories of BAJA SAEINDIA, the aBAJA category aims to expose students to autonomous mobility by introducing driver assistance features to the electric BAJA buggy. By enabling students to work with both hardware and software, BAJA SAEINDIA aims to prepare them for the future.

BAJA SAEINDIA 2026 Events will be conducted in 2 Phases:

1. Phase 1 - Preliminary Round
2. Phase 2 - Virtual and Physical Dynamic Events

- **Registration for the above-mentioned event phases would be common.**
- **The participation of international teams will be allowed in all three phases of BAJA SAEINDIA 2026.**
- **Locations will change yearly and are dependent on local support of SAE Sections, Institutes and Sponsor Companies.**

- Please refer [BAJA SAEINDIA Forum](#) and [BAJA SAEINDIA Website](#) regularly for details regarding event dates and schedules.

A.2.2 Official Announcements

Teams are required to read the articles posted on the [BAJA SAEINDIA® Website](#) and [BAJA SAEINDIA Forum](#) published by BAJA SAEINDIA® Organizing Committee. Teams must also be familiar with all official announcements concerning the competitions and rules clarifications released by the BAJA SAEINDIA® Organizing Committee.

 [BAJA SAEINDIA Forum](#) accounts of the registered teams shall be created, and the credentials shall be shared to their official team e-mail ids given at the time of registration, in due time after the closure of registrations.

A.2.3 Official Languages

The official language of the BAJA SAE® Series is English. Document submissions, presentations, and discussions in English are acceptable at all competitions in the series. Team members, judges, and officials at non-U.S. competition events may use their respective national languages for document submissions, presentations, and discussions if all the parties involved agree to the use of that language.

A.2.4 SAEINDIA Technical Standards Access

A list of accessible SAEINDIA Technical Standards can be found in Part G: Appendices - Article 2. For getting access to those standards registered teams may send the specific request to the Knowledge Centre of ARAI Pune / SAEINDIA Western Section Pune at mail id: executive-ws@saeindia.org

ARTICLE A.3: BAJA SAEINDIA® RULES AND ORGANIZER AUTHORITY

A.3.1 Rules Authority

The BAJA SAEINDIA® Rules are the responsibility of the BAJA SAEINDIA® Rules Committee and are issued under the authority of the BAJA SAEINDIA® Organizing Committee. Official announcements from the BAJA SAEINDIA® Organizing Committee shall be considered part of and have the same validity as these rules. Ambiguities or questions concerning the meaning or intent of these rules will be resolved by the BAJA SAEINDIA® Rules Committee, Technical Inspectors, or Organizing Committee during the competition onsite.

A.3.2 Rules Validity

The newest version of the BAJA SAEINDIA® Rules posted on the [BAJA SAEINDIA® Website](#) and [BAJA SAEINDIA Forum](#) and dated for the calendar year of the competition are the rules in effect for the competition. Rule sets dated for other years or older versions of the current year are invalid.

A.3.3 Rules Compliance

By entering a BAJA SAEINDIA® competition, the team members, faculty advisors, and other personnel of the entering university agree to comply with and be bound by, the rules and all rules' interpretations or procedures issued or announced by the BAJA SAEINDIA® Rules Committee and the Organizing Committee. All team members, faculty advisors, and other university representatives are required to cooperate with, and follow all instructions from competition organizers, officials, and judges.

A.3.4 Rules Comprehension

Teams are responsible for reading, understanding, and comprehending the rules in their entirety for the competition in which they are participating. The section and paragraph headings in these rules are provided to facilitate reading: they do not fully explain all the paragraph contents. Questions regarding rules may be submitted by registered teams through [BAJA SAEINDIA Forum](#).

A.3.5 Rules Questions

A.3.5.1 Privacy

By submitting a rules inquiry on [BAJA SAEINDIA Forum](#), the submitter agrees that both question and the Organizing Committee's/Technical Evaluation Team's answer can be reproduced and distributed by SAEINDIA, in edited versions, in any medium or format anywhere in the world.

A.3.5.2 Duplication

The Organizing Committee/Technical Evaluation Team will answer questions that are not already answered in the rules or FAQs or that require new or novel rule interpretations. For example, if a rule specifies a minimum dimension for a part, the Technical Evaluation Team will not answer questions asking if a smaller dimension can be used.

A.3.5.3 Submission

If a registered team has any Questions regarding rules (except such that can be classified under A.3.5.2), it can submit the inquiry through [BAJA SAEINDIA Forum](#).

A.3.5.4 Documentation

Teams submitting questions are required to bring copies of the questions and answers with them to technical inspection.

A.3.5.5 Response Time

Please allow a minimum of two (2) weeks for a response. The Organizing Committee/Technical Evaluation Team will respond as quickly as possible. However, responses to questions presenting new issues, or of unusual complexity, may take more than two weeks.

 **Please keep in mind that the final operating approval of any BAJA SAEINDIA® vehicle can only be given onsite at the competition.**

A.3.6 Loopholes

A set of rules can't be so comprehensive that it covers all possible questions about the vehicle's design parameters or the conduct of the competition. Please keep in mind that safety remains paramount during BAJA SAEINDIA®, so any perceived loopholes should be resolved in the direction of increased safety of the competition.

A.3.7 Participating in the Competition

Teams, team members as individuals, faculty advisors, and other representatives of a registered university who are present on-site at a competition are considered to be "participating in the competition" from the time they arrive at the event site until they depart the site after the competition or earlier by withdrawing.

A.3.8 Violations of Intent

The violation of the intent of a rule will be considered a violation of the rule itself. Questions about the intent or meaning of a rule may be addressed to BAJA SAEINDIA® Organizing Committee or Technical Inspectors.

A.3.9 Right to Impound

BAJA SAEINDIA® Organizing Committee reserves the right to impound any on-site registered vehicle at any time during a competition for inspection and examination by the organizers, officials, and technical inspectors.

A.3.10 General Authority

BAJA SAEINDIA® Organizing Committee reserves the right to revise the schedule of any competition and/or

interpret or modify the competition rules at any time and in any manner that is, in their sole judgment, required for the safe and efficient operation of the event or the BAJA SAEINDIA® series as a whole.

A.3.11 Force Majeure

The **BAJA SAEINDIA® Organizing Committee** and **SAEINDIA** shall not be held responsible for the non-fulfillment of their obligations as the organizers of the BAJA SAEINDIA® event due to the exigency of one or more of the **Force Majeure** events such as but not limited to the acts of God, war, flood, earthquake, strikes, lockouts, pandemics, epidemics, riots, civil commotion, scarcity of water, electricity or other such basic facilities, etc., and shall inform the participating colleges on the occurrence and cessation of the event within one week of such decision being made. If the Force Majeure conditions continue beyond a reasonable period where running the event is not feasible either due to the Force Majeure conditions or any other reasons, the event may be canceled for the year.

“Force Majeure Events”:-

- a. Earthquake, flood, inundation, landslide, storm, tempest, hurricane, cyclone, lightning, thunder, pandemics, epidemics or other extreme atmospheric disturbances, or any other act of God.
- b. Strikes, labor disruptions, or any other industrial disturbances not arising on account of the acts or omissions of the organizers, war, hostilities (whether declared or not), invasion, the act of a foreign enemy, terrorism, rebellion, riots, weapon conflict or military actions, civil war, ionizing, radiation, contamination by radioactivity from nuclear fuel, any nuclear waste, radioactive toxic explosion, volcanic eruptions or other such occurrences beyond the control of the organizers.
- c. Acts of expropriation, compulsory acquisition, or takeover by any government agency of the said venue where the event is to be held or any part thereof.
- d. Any prohibitory order of any Court.

A.3.12 Protests and Appeals

It is recognized that hundreds of hours of work are put into the design and construction of a vehicle. In the heat of competition, emotions may peak, and disputes can arise. The BAJA SAEINDIA® Organizing Committee will make every effort to fully review all questions and resolve problems quickly and efficiently.

A.3.12.1 Preliminary Review

If a team has a question about scoring, judging, policies, or any official action it must be brought to the attention of the Convener/Joint Convener (this may be designated) of the BAJA SAEINDIA® for an informal preliminary review.

A.3.12.2 Cause

A team may protest any rule interpretation, score, or official action (unless specifically excluded from protest) that they feel has caused some actual, non-trivial harm to their team, or has had a substantive effect on their score. Teams may not protest rule interpretations or actions that have not caused them any substantive damage.

A.3.12.3 Format and Forfeit

All protests must be filed in writing and presented to the relevant committee (there will be three committees - Technical Evaluation Committee, Static Events Committee, and Dynamic Events Committee) by the team captain or a designated student team member. To have a protest considered, a team must post a twenty-five (25) point protest bond, which will be forfeited if the protest is rejected.

 **Any of the above-designated committees of BAJA SAEINDIA, judges, or volunteers will not review any video footage as part of the protest.**

A.3.12.4 Protest Period

Protest related to the Event

Protests concerning any aspect of the competition must be filed within 30 minutes of the end of the event to which the protest relates.

Protest related to Scores

Protests concerning scores awarded to the teams in any of the events of the BAJA SAEINDIA competition must be filed within 30 minutes of the scores released on the BAJA SAEINDIA Forum.

 **The Scores will be released on BAJA SAEINDIA Forum only between 9:00 am and 9:00 pm IST. Teams are required to check [BAJA SAEINDIA Forum](#) regularly for any updates about the event or scores.**

A.3.12.5 Hearing

The time of protest will be noted and decided upon by the designated committee.

A.3.12.6 Decision

The decision regarding any protest is final.

A.3.13 Prohibited Actions

To ensure the safety, fairness, and integrity of the event, the following actions are strictly prohibited. Any team found violating will be levied the specified penalties for each instance of non-compliance as under, and these penalties will be deducted from their overall event scores.

Prohibited Actions	Penalty
Speeding the vehicle at more than walking pace while moving it to various event sites	25
Team members found inside the event site after 9 PM or event site closure time based upon the PA announcement whichever is earlier	100
Consuming alcohol/drugs or smoking inside the event location	100
Driving the vehicle without completing the fitment of all components and protective covers	50
Testing and running the vehicle on any undefined area during the BAJA SAEINDIA event endangering safety	50
Receiving outside assistance whatsoever from any skilled worker, team alumni, or college staff at the event site	100
If team members (except driver(s)), faculty, family members, college alumni are present on the endurance race track or dynamic event track	100
Any member other than the designated team driver(s) driving the vehicle under any circumstances	25
Cranking the engine in the pit areas post clearing the Engine Inspection	50
Performing cutting, grinding, drilling, welding, etc., operations inside the pit and hot pit without using personal protective equipment (gloves, goggles, etc.)	50
Performing any kind of repair work in areas outside the event site or other than designated area	100
Any person apart from the team members and the faculty advisors is present inside the allotted pit of the respective teams	25

Fueling the vehicle or carrying fuel inside the pit	50
Performing welding operation inside the pit	50
Taking the supporting frame or structure of pit banners.	25

- Any actions not mentioned above but found to affect the safety, fairness, and integrity of the event will be penalized as per the discretion of the BAJA SAEINDIA Organizing Committee.

ARTICLE A.4: PARTICIPATION REQUIREMENTS

A.4.1 Students

A.4.1.1 Eligibility

Eligibility to compete is limited to undergraduate and postgraduate students to ensure this is an engineering education rather than a race. Individual members of teams participating in this competition must satisfy the following requirements:

A.4.1.2 Student Status

Team members must be enrolled as degree seeking undergraduate or postgraduate student in a college or university. Team members who have already graduated prior to the competition are NOT eligible to participate.

A.4.1.3 Society Membership

Members of Indian Teams must be members of SAEINDIA (<https://saeindia.org/become-a-member/>). It is mandatory for members who are enrolling for a new SAEINDIA Membership to select the current year+1 year type exclusively.

The SAEINDIA Membership year for new enrolment is considered from April 1st 2025 to March 31st 2026.

In case any BAJA SAEINDIA 2026 event takes place after 31st March 2026, registered SAEINDIA members whose membership is expiring will be considered participants only, if they have submitted their SAEINDIA membership cards before March 31st, 2026. This policy is applicable to already registered SAEINDIA members only.

Members of International Teams must be members of at least one of the following societies

- Local automotive associations like the Institution of Automotive Engineers, etc.
- SAE International ([SAE International](#)) or an SAE International affiliate society
- FISITA ([Join FISITA](#)) or societies that are members of FISITA ([FISITA Society Members](#))

- In case any team willing to participate is not a part of any of the associations listed above, they must write to BAJA SAEINDIA® Organizing Committee at bajasaeeindiacommunications@saeindia.org with a copy to saeindiaindore@saeindia.org for further clarification.

Proof of membership, such as a valid membership card is required while registering for the event and also needs to be produced during the event to participate in the BAJA SAEINDIA® competition.

For more information regarding society membership, please contact saeindiaindore@saeindia.org (For SAEINDIA) or collegiatecompetitions@sae.org (For SAE International).

A.4.1.4 Age

Team members must be at least eighteen (18) years of age at the time of the competition.

A.4.1.5 Driver's License

Team members who will drive a competition vehicle at any time during a competition must hold a valid, government-issued driver's license.

A.4.1.6 Indemnity Bond

All on-site participants and faculty are required to bring a notarized indemnity bond to be submitted at the time of registration on-site. All the members and faculty to be present on-site are required to sign the indemnity bond.

A.4.1.7 Insurance

Individual medical and accident insurance coverage is required and is the sole responsibility of the participant.

A.4.2 Faculty Advisors

A.4.2.1 Faculty Advisor Status

Each team is expected and encouraged to have at least one and a maximum of two Faculty Advisors appointed by the college/university. The faculty advisor/s will be considered by competition officials to be the official university representative accompanying the team. Their presence during the competition is **mandatory** for all the event days on-site.

Faculty advisor/s of the participating Indian Teams must be members of SAEINDIA (<https://saeindia.org/become-a-member/>).

Faculty advisor/s of International Teams must be members of at least one of the following societies

- Local automotive associations like the Institution of Automotive Engineers, etc.
- SAE International ([SAE International](#)) or an SAE International affiliate society
- FISITA ([Join FISITA](#)) or societies that are members of FISITA ([FISITA Society Members](#))

In case any team willing to participate is not a part of any of the associations listed above, they must write to BAJA SAEINDIA® Organizing Committee at bajasaeindiaindore@saeindia.org with a copy to saeindiaindore@saeindia.org for further clarification.

It is mandatory for faculty advisor(s) to accompany the team during the physical dynamic event and at least one Faculty Advisor must be present with the team for the entire event duration, the absence of which will lead to a penalty of 100 points, as per the discretion of BAJA SAEINDIA® Organizing Committee.

A.4.2.2 Age

Faculty Advisors must be at least eighteen (18) years of age at the time of the competition.

A.4.2.3 Indemnity Bond

All on-site participants and faculty are required to bring a notarized indemnity bond to be submitted at the time of registration on-site. All the members and faculty to be present on-site are required to sign the indemnity bond.

A.4.2.4 Faculty Advisor Responsibilities

Faculty Advisors are expected to advise their teams on general engineering and engineering project management theory. She/he may: -

- Advise, review, and monitor the progress of the team for the overall design, development, manufacturing, and testing of the BAJA vehicle.
- Ensure the safety of the vehicle and facilitation of in-house manufacturing within the college premises.

- Support and assist the BAJA SAEINDIA® Organizing Committee to conduct the event peacefully and in case of any disputes arising during the competition, help to resolve those.
- Accompany the team at the main event site and be present with the vehicle during technical evaluation, brake test, static events, and dynamic events.

A.4.2.5 Faculty Advisor Limitations

Faculty advisors must not design any part of the vehicle or any system of the vehicle nor directly participate in the development of any documentation or presentation.

Faculty Advisors or college staff should neither fabricate nor assemble any components nor assist in the preparation, maintenance, testing, or any operation of the vehicle.

Faculty Advisors may remain present during the technical inspection, cost audit, or design presentations. The team captain or other designated members of the team must do all the presenting work. However, Faculty Advisors may silently observe the process and work towards improvement in future participation years of the college/university.

Faculty Advisors cannot get involved directly in the design, build or repair of any part of the vehicle.

A.4.3 Visa Requests

International Teams can request a Registration Confirmation Letter for the individual event(s) that they will be attending, by sending an email to bajasaeindiaindicommunications@saeindia.org. In response to the same, they shall be provided personalized letter/s with the following information: Registered Student's Name, School's Name, the BAJA SAEINDIA® Event Name, Official Dates, and Location(s).

Caution: SAEINDIA cannot and will not intervene with, call or send personal letters to, the State Departments, Embassies, or Consulates of India or other governments on behalf of any meeting or event participant.

Caution: Apply early for visas.

Neither SAEINDIA staff nor any competition organizers are permitted to advise on visas, customs regulations, or vehicle shipping. Nor will they intervene on either matter concerning India or any other country.

ARTICLE A.5: VEHICLE ELIGIBILITY

A.5.1 Student Created

The vehicle and associated documentation must be conceived, designed, manufactured, and fabricated by the team members without direct involvement from professional engineers, faculty, or professionals in the off-road and racing communities. Proof of manufacturing location may be required to be furnished by the teams on-site upon being asked by the officials.

A.5.2 Professional Fabrication Limits

1. Without exception, only those teams whose college management gives an undertaking allowing the use of their workshop facilities would be allowed to participate. Additionally, teams need to submit a list of operating facilities/equipment available with the college that will be used to fabricate and assemble the vehicle as per the design presented in the Preliminary Round of the BAJA SAEINDIA® event.
2. During the actual manufacturing and fabrication process, the video clips that cover students working in a college facility need to be taken and written on a CD/ downloaded on a pen drive, to be furnished anytime throughout the project. The video clip is required to cover each of the manufacturing processes carried out in college.
3. Extensive use of readymade subassemblies may invoke penalties. Vehicles that have been professionally fabricated may be penalized up to 400 points or disqualified from the competition. The decision of the organizing committee in this regard will be final. In such a case, the registration fee would NOT be refunded.
4. During the main event if any team is found to be receiving outside assistance at the event site, the

team will be penalized with 100 points at the first incident and subsequent act will lead to Disqualification from the event.

A.5.3 Kit Vehicles Prohibited

Vehicles fabricated from a kit or published designs are ineligible to compete. Vehicles that have been professionally fabricated will be disqualified from the competition or receive a penalty. In case a team does not have access to machine shop facilities, the frame can be professionally fabricated without a penalty attached. Lack of access must be documented (letter from the faculty advisor, copy of policies that prohibit machine shop access, etc.).

A.5.4 Prefabricated Subassemblies

These rules do not exclude the use of prefabricated or modified sub-assemblies. However, extensive use of readymade subassemblies may invoke penalties. The list of prefabricated parts that may be allowed is – shock absorbers, coil springs, brake drum, brake disc, brake calipers, brake holding assembly, master cylinder, steering gear box, and steering column, steering wheel, wheel rims and tires, seat frame, tie rod ends. For hBAJA teams - Engine, fuel tank, and exhaust system - complete assembly supplied from B & S to be used.

All other parts need to be fabricated in-house and are not permitted to be outsourced from professional/other manufacturers/ designers.

Any outsourcing must be reflected in the cost report with supporting receipts from the outsourcing vendor.

A.5.5 Bills and Document

For all procured items, teams must submit original tax invoices. In case of an electronic copy of bills, the team **MUST** carry a printed copy signed by the Faculty Advisor, HOD, and Accounts Department of College, along with the college's stamp on it.

- ✔ **For items whose original bills are retained by college authorities, teams must submit photocopied bills signed by the Faculty Advisor, HOD, and Accounts Section of the College, along with the college's stamp on them.**

A.5.6 Vehicle Usage Restrictions

Team must make a note that, the BAJA SAEINDIA® competition vehicles are not CMVR approved vehicles to ply on public road. Therefore, the testing and usage on public road is strictly prohibited. This means that none of the teams will test or make a trial on public road and public places/grounds, etc. The legal compliance is strictly team's responsibility and SAEINDIA or BAJA SAEINDIA® Organizing Committee is not responsible for any non-compliances or any implications of violation by any team.

ARTICLE A.6: REGISTRATION

A.6.1 Individual Registration

A.6.1.1 SAE Membership

A.6.1.1.1 SAEINDIA Membership (For Indian Teams)

Please note all student participants and faculty advisors of Indian teams must be SAEINDIA members to participate in the event.

All participating Institutes from India must have an operational SAEINDIA collegiate club with at least 50 active student members and 2 faculty advisors. ([SAEINDIA Collegiate Club Formation Guidelines](#))

For membership of student's/faculty advisors with SAEINDIA, visit - (<https://saeindia.org/become-a-member/>)

Faculty advisors should choose an option under the "Professional Registration" link.

For details on membership or Collegiate Club, please visit www.saeindia.org or contact the below SAEINDIA representatives.

Ms. Sowmiya Assistant (Membership) – SAEINDIA sowmiya@saeindia.org	Ms. Jean Sophiya Shiny Officer – SAEINDIA shiny@saeindia.org	Mr. Himanshu Maru BAJA Secretariat - Indore saeindia_indore@saeindia.org
SAEINDIA HQ – Contact Number: +91-44 2441 1904, +91-44 4332 7336		

A.6.1.1.2 SAE International Membership (For International Teams)

Please note all the student participants and faculty advisors of International Teams must be members of at least one of the following societies:

- Local automotive associations like the Institution of Automotive Engineers, etc.
- SAE International ([SAE International](http://www.saeindia.org)) or an SAE International affiliate society

For membership of students with SAE International, visit - [SAE International](http://www.saeindia.org) and click Join Today

Faculty advisors should choose an option under the “Professional Membership” link - [SAE International](http://www.saeindia.org)

- FISITA ([Join FISITA](http://www.fisita.org)) or societies that are members of FISITA ([FISITA Society Members](http://www.fisita.org))

In case any team willing to participate is not a part of any of the associations listed above, they must write to BAJA SAEINDIA® Organizing Committee at bajasaeindiaindore@saeindia.org with a copy to saeindiaindore@saeindia.org for further clarification.

A.6.2 Team Registration

A.6.2.1 Online Registration

Registration for the BAJA SAEINDIA® event held in India must be completed online on the [BAJA SAEINDIA Website](http://www.saeindia.org). Online registration must be done by either (a) An SAEINDIA or SAE International (For International teams) or a member of other allowed societies (for international teams) or (b) the official faculty advisor connected with the university and recorded as such in the SAEINDIA or SAE International (For International Teams) or any other allowed societies (for international teams) record system.

An active SAEINDIA collegiate club is required for the Indian colleges to register the team. Also, the collegiate club should have an active SAEINDIA collegiate bank account and bank details must be available before the competition.

A.6.2.1.1 International team registration

Teams interested to participate in BAJA SAEINDIA® shall visit the [BAJA SAEINDIA Website](http://www.saeindia.org) and register as per the latest version of BAJA SAEINDIA® Registration Guidelines for the calendar year.

A.6.2.1.2 Multiple Event Participation

Teams willing to participate in more than one event with same team members can refer the below enclosed table.

Sr.No.	College Participating in	Common Team Members
1	mBAJA & hBAJA	Not Allowed
2	eBAJA & aBAJA	Allowed
3	mBAJA & eBAJA	
4	mBAJA & aBAJA	
5	eBAJA & hBAJA	
6	hBAJA & aBAJA	
*Only mBAJA and hBAJA Teams are not allowed to register common team members.		

A.6.2.1.3 Onsite Registration

An Onsite verification will be done during phase 2 of the BAJA SAEINDIA event.

- Teams need to submit the indemnity bond on the [BAJA SAEINDIA Website](#). The format of the indemnity bond will be shared on [BAJA SAEINDIA Forum](#) closer to the event dates.
- After verification teams will receive a confirmation mail about the successful online submission of documents.
- The teams need to carry the printout of the successful online submission confirmation mail and submit it at the respective registration bay as per the slotting.
- Any member of the team can submit the confirmation mail printout along with the indemnity bond, and letter of deviation if applicable and obtain their respective registration kit.

A.6.2.2 Team Size

Team Members	5 [Minimum]	25+5+10 [Maximum]
Faculty Advisors	1 [Minimum]	2 [Maximum]

- To promote diversity amongst the teams; If the team has reached the 25 members limit, they can add 5 more girl team members without any additional amount in the registration fee. Thus, the number of total team members in such a case should not exceed 30.
- Team Can Add up to 10 additional members beyond the 30-member limit by paying ₹1,500 per male Student member and 1,000 per female student member on or before **30th September 2025**
- These members must have a valid SAEINDIA membership card and should be in their 1st or 2nd year of Engineering as of **30th January 2026**. They will only participate as team members and cannot take on roles such as Captain, Vice-Captain, Co-Driver, or Driver.
- These members will be designated as Interns, and upon successful participation, they will receive an Internship Certificate, acknowledging their attendance at the event to gain practical exposure and learning experience.
- This initiative aims to provide younger students with valuable learning and exposure at BAJA.
- Registration of multiple teams from the same college on different event format will be allowed for BAJA SAEINDIA 2026 event under different heads.
- It is mandatory for faculty advisor(s) to accompany the team during the main physical event and a minimum of 1 Faculty Advisor must be present with the team for the entire event duration.
- hBAJA teams must contain a minimum of 2 members and maximum of 12 members from Electrical/ Electronics/ Instrumentation/ Mechatronics / Computer science and/or other similar backgrounds to successfully complete the registration process.
- Teams that participated in any of the last two physical hBAJA events are eligible to compete in hBAJA, using either their old or current hBAJA vehicle.** Teams with older vehicles must ensure that components such as tyres, shock absorbers/fox suspension, CVT, and the driver's seat have not been in use for more than **three years.**
- hBAJA teams can comprise of members pursuing undergraduate and postgraduate studies from the same college/institution/Deemed University within the member's limit.**

Note: - This is being done in line with the advent of Autonomous drive technology in the Automotive Industry, undergoing disruption is to learn towards latest trends in Mobility industry. Hence, BAJA SAEINDIA has taken this initiative to promote inter-disciplinary engineering among the teams.

- ☑ **Teams are advised to take proper care while forming the team before initial registration for Preliminary Round and refrain from further modification at a later date. Before Phase 1 Teams have to register at least 5 Team members and 1 Faculty Advisor. Post Phase 1 Profile of all teams will be unlocked for 1 week for addition of remaining Team Members and Faculty Advisor. Exceptional cases such as death, natural calamity, etc. shall be dealt with separately. In such cases a letter on the Institution's/College's letterhead with a declaration from the Institution's Head / Principal is mandatory. Backing-out or withdrawal of any member from the team, due to any reason other than "exceptional" as mentioned above, is NOT permitted. Penalties for the same will have to be borne by the team.**



A.6.2.3 Registration Dates

Teams must register for the BAJA SAEINDIA® competition by the specified date as published in the latest version of BAJA SAEINDIA® Registration Guidelines for the calendar year.

A.6.2.4 Registration Fees

Registration fees must be paid to the organizer by the deadline specified on the latest versions of Registrations Guidelines for the calendar year. Registration fees are not refundable and not transferrable to any other competition. Registration fees for the BAJA SAEINDIA® event are taken in two phases, please refer to the latest version of BAJA SAEINDIA® Registration Guidelines at the time of registration.

The registration fee for BAJA SAEINDIA® must be paid through payment mode as mentioned in the latest version of BAJA SAEINDIA® Registration Guidelines at the time of registration. The exact deadlines for the payment of registration fees for each event phase shall be notified to the teams at the pertinent time, while the requisite fees to be paid for each event phase shall be as stated in the Registration Guidelines.

Registration Fee is NON-REFUNDABLE and will not be returned to the teams under any circumstances.

GST is applicable @ 18% for the registration fees and non-refundable, which means once SAEINDIA collects the GST, the same will be remitted to the Government within the due date and not be returned to the teams under any circumstances.

GST invoices will be issued in the below two types:

1. Unregistered category (B to C) for which the college cannot avail of ITC (Input Tax Credit).
2. Registered Category (B to B) for which college can avail ITC – The respective college needs to submit the GST No. on the portal during payment.

Kindly note that going forward BAJA SAEINDIA will not entertain any request related to GST Modification or B2B Invoice if the team have not submitted the above said details during payment.

A.6.2.4.1 Registration Fees Waiver

- **All Girls Team Waiver:** For RETURNING All Girls team, up to 25% discount on overall registration fees, and for NEW All Girls Teams up to 50% discount on overall registration fees in both phases excluding fee waiver amount.
- **Debut Team Waivers:**

Teams meeting any of the following criteria below are classified as Debut Teams:

1. Teams entering BAJA SAEINDIA for the first time.
2. Instances where a NEW team from a college joins a new category while the RETURNING team from

the same college continues participation in another category until Phase 3.

3. Teams transferring between categories and registering as NEW teams in the newly selected category.

The team meeting any one of the aforementioned criteria will be eligible for up to a 10% discount on the overall registration fee.

The definition of new and returning team is mentioned in the latest version of BAJA SAEINDIA® registration guidelines

- **hBAJA Subsidy (Applicable to all hBAJA teams participating in the Physical Round) :**
The team fulfilling the following criteria will qualify to receive reimbursement equivalent to 75% of registration fees excluding fee waiver amount:
 1. The team must attempt all the dynamic events at least once.
 2. The team must complete a minimum of 75% of endurance race.
- **Promoting Women's Inclusion Subsidy:**
If a team in Physical Round includes 10 or more female participants, they will qualify for a reimbursement equivalent of up to INR 10,000 after the conclusion of the season.

NOTE: THE ABOVE WAIVER WOULD BE APPLICABLE TO ALL THE NON-ALL-GIRL TEAMS OVER AND ABOVE THE WAIVERS MENTIONED ABOVE TO PROMOTE MORE INCLUSIVE BAJA SAEINDIA.

In case of any further queries or clarifications, we recommend the teams to contact BAJA SAEINDIA to get those cleared and refrain from making their assumptions.

Mr. S Hariharan	Mr. Joel Jo Thomas
Convener – Virtual Round	BAJA Alumni Committee Head
+91 9977817993	+91 8078460802
hariharan.baja@gmail.com	thomasjoeljo@gmail.com
BAJA SAEINDIA Email ID	bajasaeindiaindicommunications@saeindia.org
BAJA SAEINDIA Forum	bajasaeindiaforum.com
BAJA SAEINDIA Website	www.bajasaeindia.org

A.6.2.5 Withdrawals

Registered teams for the BAJA SAEINDIA® events that determine they will not be able to attend the competition are required to officially withdraw by emailing bajasaeindiaindicommunications@saeindia.org with a copy to saeindiaindore@saeindia.org no later than 15 days before the event. Registration fees are NOT refundable or transferable.

A.6.2.6 Failure to Meet Deadlines -

All teams registered for the BAJA SAEINDIA® competition are required to submit all required documents before the competition. The required documents provide evidence their car complies with the frame rules, supports the technical inspection process, and provides material that the Cost and Design event judges need to evaluate the team during the competition. When these documents are not submitted, the judges cannot properly assess the vehicle or the team.

Additionally, failure to submit the required Cost, Design, Business Presentation Plan, and Technical Documents

is a clear violation of the rules. Any blank document submitted to subvert the submission date will be treated as a failure to submit.

Therefore, it is the policy of BAJA SAEINDIA® that failure to submit the required Cost, Design, Sales Presentation Plan, or technical documents within five (5) days of the deadline will constitute an automatic withdrawal of your team from the respective static event.

A.6.2.7 International Participation – Vehicle Shipping and Customs

BAJA SAEINDIA® Organizing Committee strongly recommends international teams ship their vehicles early to allow enough time to compensate for any delays that may occur in clearing Indian Customs. Please check with the Indian Customs Service concerning the regulations governing the temporary importation of vehicles. Teams may want to consider using the services of a freight forwarder, who is familiar with the international shipping of racing vehicles.

Vehicle shipments by the commercial carrier must comply with the laws and regulations of the nations from which, and to which, the vehicle is being sent. Teams are advised to consult with their shipping company or freight forwarder to be sure their shipment fully complies with all relevant customs, import/export, and aviation shipping requirements.

Shipments must be sent with the participating university listed as the receiving party. The competition organizers, SAEINDIA Staff, nor the competition sites can be listed as the receiving party for your vehicle.

The vehicle shipping procedure for the BAJA SAEINDIA® competition shall be published on the [BAJA SAEINDIA Forum](#) and is incorporated into these rules by reference. Neither BAJA SAEINDIA® Organizing Committee nor SAEINDIA staff is permitted to provide advice on Indian Custom matters.

A.6.2.8 Mentoring

After successful registration, hBAJA teams will be assigned mentors for advising the teams on vehicle design, manufacturing and testing. Mentors shall guide the teams on sound engineering practices, application of various technologies that need to be integrated to make it hydrogen powered, and understanding of the rulebook, etc. Mentors will not directly assist the team in designing, manufacturing, or testing, and only provide advisory inputs as and when required by the teams.

ARTICLE A.7: REQUIRED EVENT SUBMISSIONS

A.7.1 Required Event Submissions

All required reports or other documents and/or files shall be submitted through the [BAJA SAEINDIA Website](#). The standard forms and/or templates and/or guidelines that are required for documentation and submissions at BAJA SAEINDIA® competitions shall be posted on [BAJA SAEINDIA Forum](#).

A.7.1.1 Responsibilities and Restrictions

There will be only a single account for a team on the [BAJA SAEINDIA Website](#).

Uploading Documents - All the requisite documents and/or files can be submitted by the team only once on the [BAJA SAEINDIA Website](#). Teams to note that once submitted, they cannot replace or change the submitted documents and/or files.

Document Access - Uploaded documents can only be viewed by (1) members of the submitting team, (2) authorized judges, technical inspectors, and officials, and (3) BAJA SAEINDIA® staff.

Reminder - The website does not know what is intended for submission or what the submitter is thinking. Anything a team uploads to the site is considered to be an official action by the team.

A.7.1.2 Process

Teams competing in BAJA SAEINDIA® competitions must submit the required documents and/or files online through the BAJA SAEINDIA Website. Documents and/or files must be uploaded on the website from the time submission is started until the due date

A.7.1.3 Deadline

Submissions must be received by the due date listed on the [BAJA SAEINDIA Forum](#) and/or [BAJA SAEINDIA Website](#).

Submission will be acknowledged on the [BAJA SAEINDIA Website](#) with a visual indicator. Teams should have a printed copy of this acknowledgment available at the competition as proof of submission in the event of a discrepancy.

A.7.1.4 Late Submission / Non-Submission Penalty

Late submission or failure to submit the Design Report and/or Sales Presentation Plan and/or Cost Report and/or any other required submissions will be penalized, as per the discretion of the BAJA SAEINDIA® Organizing Committee. If either report is received late after the due date, it will be classified as “Not Submitted” and will result in an automatic withdrawal of your team from the respective static event.

PART B: TECHNICAL REQUIRMENTS

ARTICLE B.1: GENERAL DESIGN REQUIREMENTS

B.1.1 General Requirements

The vehicle must be capable of carrying one (1) person 190 cm (75 in.) tall weighing 113 kg (250 lbs.).

B.1.2 Ergonomic Design

All drivers shall meet the roll cage minimum clearances and fit into a comfortable driving position while wearing the entire required driver's equipment. All drivers shall be able to comfortably reach all the vehicle's controls.

Teams shall be prepared to demonstrate compliance to this requirement in the design event.

B.1.3 Good Engineering Practices

Vehicles entered BAJA SAEINDIA® competitions are expected to be designed and fabricated following good engineering and construction practices.

B.1.4 All-Terrain Capability

B.1.4.1 Terrain Type

The vehicle must be capable of safe operation over rough land terrain including obstructions such as rocks, sand, logs, steep inclines, mud, and shallow water in any or all combinations and in any type of weather including rain.

B.1.4.2 Clearance and Traction

The vehicle must have adequate ground clearance and traction for the terrain type at the competition.

B.1.5 Vehicle Configuration

B.1.5.1 Wheel Arrangement

The vehicle must have four (4) or more wheels not in a straight line.

B.1.5.2 Four-Wheel Drive / All-Wheel Drive

For the 2025 competition, hBAJA teams have an option to incorporate 4WD/AWD or 2WD in their design. To be considered a 4WD/AWD vehicle, the vehicle must have a powertrain system capable of providing power to all its wheels. 4WD/AWD may be full-time (AWD) or selectable (4WD); selectable AWD/ 4WD implies provision in a vehicle to switch between 4WD and 2WD. Both wheels on the front and rear of the vehicle shall be capable of being powered. Demonstration of 4WD/AWD capability in working conditions is a must.

B.1.5.2.1 Penalties

Teams may attempt the 4WD/AWD check at any time after Engine check and before Final Technical Inspection. Teams must pass 4WD/AWD check before the "passed tech" sticker will be issued.

Teams unable to successfully pass the 4WD/AWD check will be allowed to complete the final stages of technical inspection and compete in the dynamic events and the endurance event. However, such teams will not receive their 4WD drive check clearance sticker and a 4WD non-compliance penalty will be applied where appropriate.

The non-compliance penalty for each dynamic event will be 50 percent of the maximum points that can be scored in that event, i.e. the non-compliance penalty for Specialty event will be 50 points, for the endurance

event will be 150 points, and for the remaining dynamic events will be 25 points each. The team's score for each event will not drop below zero points even if a non-compliance penalty is assessed that would otherwise result in a negative score.

B.1.6 Limitations

Width: 162 cm (64 in) at the widest point with the wheels pointing forward at static ride height.

Length: Unrestricted.

Weight: Unrestricted.

 **Teams should keep in mind that BAJA SAEINDIA® courses are designed for vehicles with the maximum dimensions of 162 cm (64 in.) in width by 274 cm (108 in.) in length.**

ARTICLE B.2: ENGINE (hBAJA Only)

B.2.1 Required Engine

Starting from the year 2026, Greaves Cotton would be providing two engines to BAJA SAEINDIA for teams participating in hBAJA with subsidized rates. One will be the regular G400WVI Bi-Fuel - CI based and second will be G395VI Bi-Fuel - Aluminium based New Engine. In addition, teams are required to pay shipping and handling charges.

To provide a uniform basis for the performance events, all vehicles shall use the same engine: an unmodified, Single Cylinder, 4-stroke, Naturally Aspirated (NA), Water cooled, electronically controlled CNG/hCNG injection engine.

Teams must refer to [BAJA SAEINDIA Forum](#) for engine ordering deadlines, and necessary payment to be made to Greaves Cotton for procurement of engine. For further notifications on Engine, ordering teams must keep updated on [BAJA SAEINDIA Forum](#). Without exception, each engine will come with a maintenance kit.

B.2.2 Engine Orders

Students are advised to purchase the engine from Greaves Cotton authorized engine supplier for BAJA SAEINDIA® events.

- Greaves make bi-fuel BSVI CNG engine model G-400WG @ Rs.40000/- – Rs 45000/- approx. (Amount & Further Details will be released separately).
- Price quoted above is on ex-works Greaves plant at Aurangabad basis on freight To Pay basis, excluding GST which shall be charged extra as applicable at the time of supply. The current rate of GST is 28%.
- Packing charges extra @ Rs.1400/- per engine.
- Payments 100% advance along with PO.
- Lead time to execute the order – 4 to 6 weeks.
- GCL Scope parts shall be supplied with the engine.

Address & Contact for Engine Ordering (Will be confirmed in Final Rulebook)

Greaves Cotton Ltd. J-2,
MIDC Industrial Area, Chikalthana,
Aurangabad – 431210
Email: sp.singh@greavescotton.com

B.2.3 International Orders

Details regarding Internal Orders will be released on BAJA SAEINDIA Forum.

B.2.3.1 Hydraulic

Hydraulic accumulators are the only type of stored energy device that may be incorporated into the vehicle for propulsion purposes. Hydraulic power systems must be properly shielded, and documentation of the shielding made available for review. Teams shall provide a hydraulic power specification sheet at the time of technical inspection.

B.2.3.2 Electric

Batteries or other electric energy storage devices for vehicle propulsion are explicitly prohibited. Hybrid electric vehicle propulsion systems are explicitly prohibited.

B.2.4 Engine Requirements and Restrictions

To provide a uniform basis for the performance events, all vehicles shall use the same engine: an unmodified, Single Cylinder, 4-stroke, Naturally Aspirated (NA), Water cooled, electronically controlled CNG injection engine.

The required engine must remain completely stock in all ways.

 **Blueprinting (reworking an engine to a manufacturer's exact specifications) is considered to be a modification and is explicitly prohibited.**

The only engine model accepted at all BAJA SAEINDIA® competitions is Greaves Cotton model number: A03G140018.

 **No other engine models will be accepted.**

B.2.4.1 Replacement Parts

Only Original Equipment Greaves Cotton replacement parts may be used. Consumable parts may be ordered on the Greaves [Cotton Website](#) or procured from an authorized Greaves Cotton dealer.

B.2.4.2 Piston Rings

Only standard size, original Greaves Cotton piston rings may be used.

B.2.4.3 Valves

In cold engine conditions, both valves tappet clearance to be maintained to 0.15 mm after turning flywheel until piston reaches T.D.C. position on compression stroke.

B.2.4.4. Shafts and Rods

The camshaft, crankshaft, connecting rod, and flywheel must not be altered or modified.

B.2.4.5 Spark Plugs

The only permitted spark plug is: FR7DE; Bosch Part No. 0241 A3 5300; Earth Electrode Gap A = 0.7 + 0.1 mm. No other spark plugs are permitted.

B.2.4.6. Flywheel Rotation

The flywheel shall not be rotated to advance or retard timing.

B.2.4.7 Air Cleaner

The air intake cleaner may be relocated, but Greaves Cotton parts must be used to relocate the air filter.

A fresh air cleaner element and a paper filter are required during On-site Technical Inspection - Engine at the BAJA SAEINDIA® competition site.

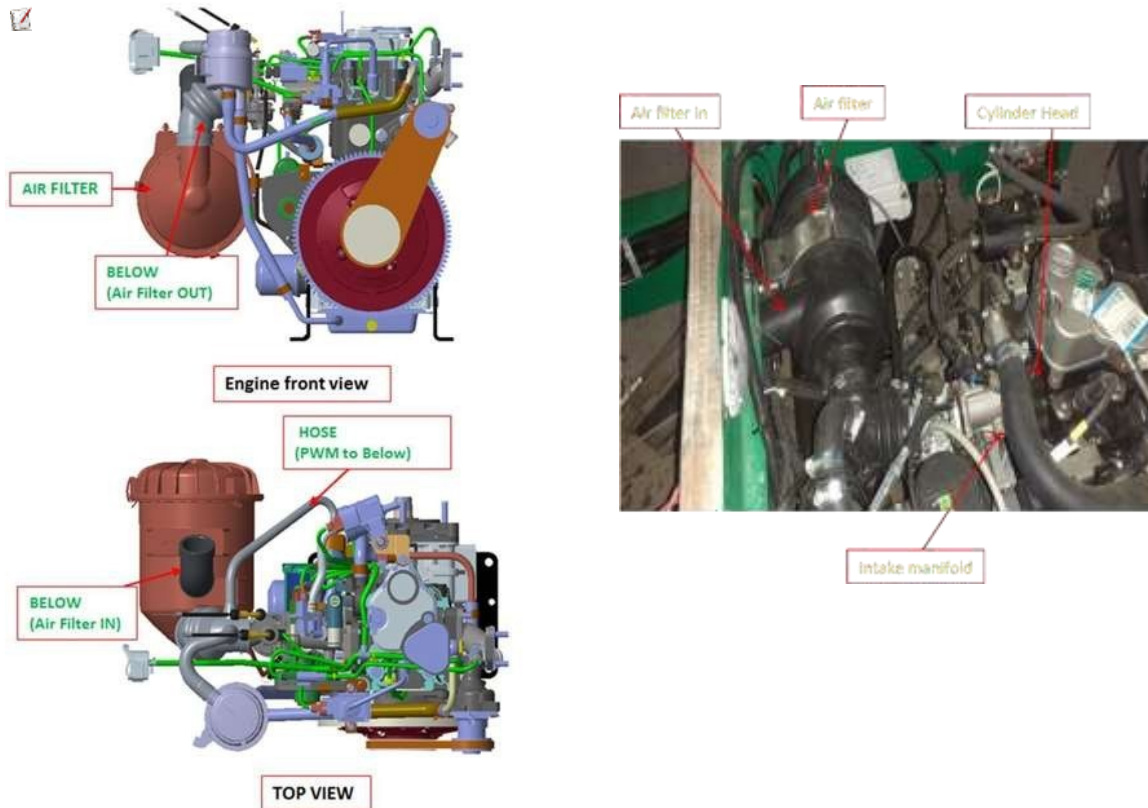

Figure 1 Air Filter Layout

Relocation of air filters or cleaner housing may decrease engine performance.

B.2.4.8 Exhaust System

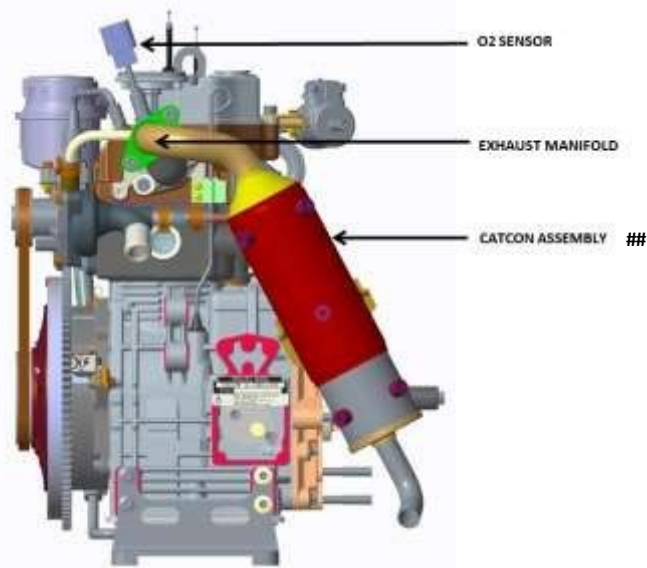

Figure 2 Engine Exhaust Layout

- CatCon Assembly in the above image is only for representation purposes, In actual Engine will be fitted with Exhaust Pipe Tube only. Teams who wish participate in Sustainability Event, can install their own after treatment device.

B.2.4.8.1 Muffler Relocation

If the vehicle design requires an exhaust system reconfiguration to keep it from impinging on part of the vehicle, the re-routing must be done as per recommendations provided by Greaves. Any remote-mounted exhaust system must use the original muffler and must be securely mounted so that it does not vibrate loose during the competition.

B.2.4.8.2 Muffler Support

Support for the exhaust pipe and muffler are required. Support must be attached exclusively to the engine.

B.2.4.8.3 Exhaust Pipe Port

The exhaust pipe may not protrude inside of the exhaust port, to alter the port configuration.

B.2.4.8.4 Exhaust Pipe Length

Any exhaust pipe length is allowed; however, pipe length may not be adjustable.

B.2.4.8.5 Exhaust Pipe Continuity

No extra holes or tubes are allowed in the exhaust pipe. One inlet and one outlet are required.

B.2.4.8.6 Exhaust Durability

The exhaust pipe and muffler must be durable, resilient, completely intact, and functional throughout the competition. Any vehicle found to have a loose or leaking exhaust system will be removed from competition until the issue can be corrected.

B.2.4.8.7 Exhaust System Complete

The complete exhaust system shall be located such that its extremities lie at least 100 mm within the perimeter of the vehicle. (The perimeter of the vehicle stands for the envelope formed by the planes of the roll cage members). (Refer figure B-2.1)

 **Engines shall not be placed in a way such that the exhaust is facing towards the firewall. In case of exhaust facing the firewall, the teams should ensure the clearance between exhaust and firewall is a minimum of 300 mm after rerouting of exhaust and which will be validated by Greaves Cotton at the main event. The team may be subjected to modifying the routing if it's not meeting the requirements of Greaves Cotton.**

B.2.4.8.8 Muffler Cage

Teams are encouraged to retain the protective wire cage surrounding the muffler to reduce the risk of burns.

B.2.5 Technical Specifications:

B.2.5.1 Technical Information:

G400WVI Bi-Fuel - CI based:

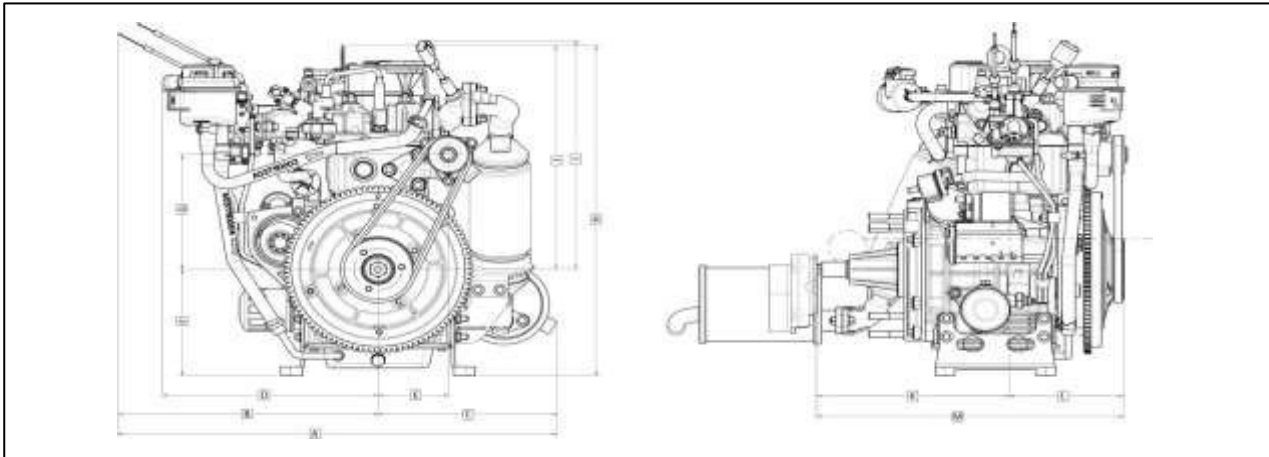

DIMENSIONS (mm)									
A	599.8	D	294	G	176.7	J	344.5	M	419.6
B	355.4	E	96	H	508.5	K	264.1		
C	244.5	F	164	I	352.4	L	155.5		
GENERAL INFORMATION									
Model				G 400 W VI					
Type				Water cooled, Naturally Aspirated, Electronically controlled Port Injection CNG/LPG Engine.					
Cylinders				Nos.			1		
Bore x stroke				mm x mm			86X68		

Displacement	Cc	396
Compression ratio	9.5: 1	
Crankshaft rotation	Anticlockwise viewed from GEAR END(PTO)COVER side	
Injection	CNG/LPG Injection	
Engine dry weight with alternator & without starter motor.	Kg	~47 kg
Installation	Vertical	
POWER AND TORQUE		
Power	HP	9.5+/-5% @ 3400rpm
Maximum torque	N-m	22.5+/-5% @ 1800-2200rpm
LUBRICATION CIRCUIT		
Engine oil capacity (With oil filter)	1.450 ±50 ml (Top up:1.4 L, In oil filter: 50-70 ml)	
Oil Filter	Spin-on full flow type	

G395VI Bi-Fuel - Aluminium based New Engine

Parameter	G395VI Bi-Fuel - Aluminium based New Engine
Engine Type	Single cylinder, 4-Stroke, Spark Ignition, Water Cooled
Application	Automotive, 3-Wheeler (CNG)
Emission compliance	BS VI
Bore X Stroke (mm)	86 X 68
Cubic Capacity (cc)	395
Dry weight (Kgs)	~ 43 kg (manifold to manifold without after treatment and oil) All aluminium engine
CNG Fuel System	Port Injection
Gasoline Fuel System	Carburetion
Rated Power, BHP	9.5 HP @ 3400 rpm
Maximum Torque (N-m)	23.5 +/-10% @ 1800-2000rpm
PTO Option on Crankshaft	Splined
Rotation	Anticlockwise (viewed from PTO side)
Size (L x W x H), mm	399 x 442 x 471

B.2.5.2 Engine Port to Port Dimensions

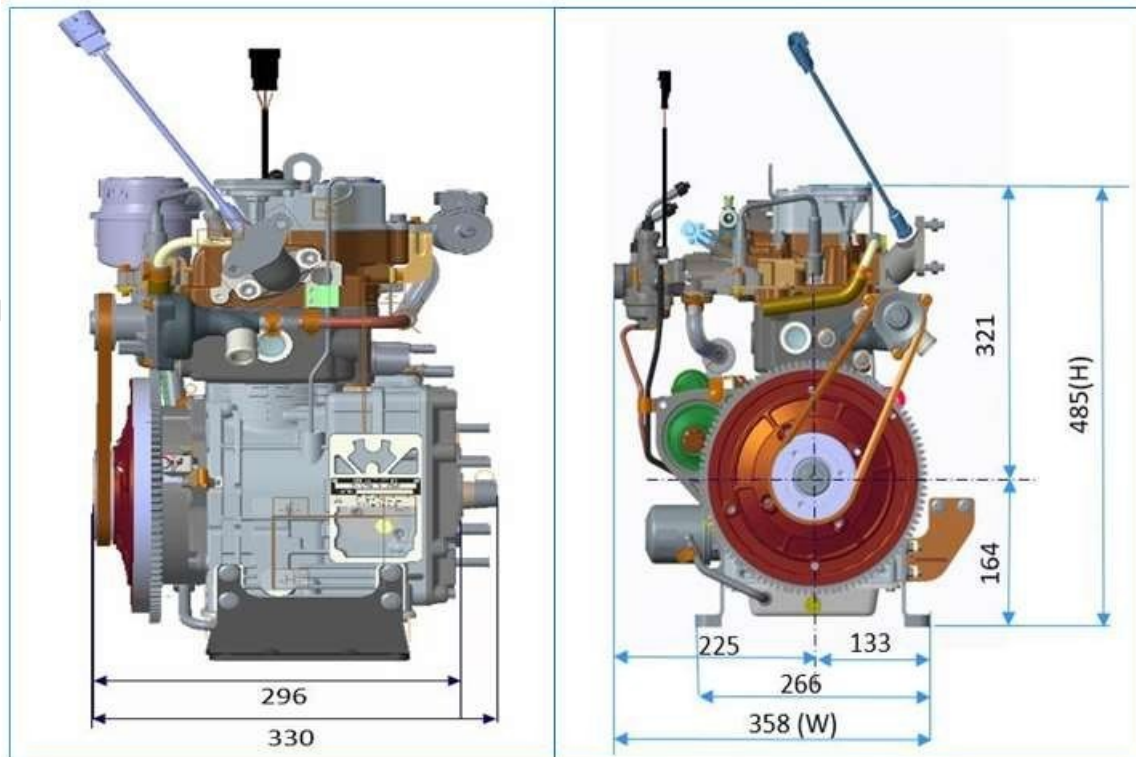

- L X B X H: 330 X 358 X 485 mm
- Flywheel Pulley to Gearbox Mounting: 300mm
- Distance Between Feet: 266mm

B.2.5.3 Engine Performance Curves

G400WVI Bi-Fuel - CI based

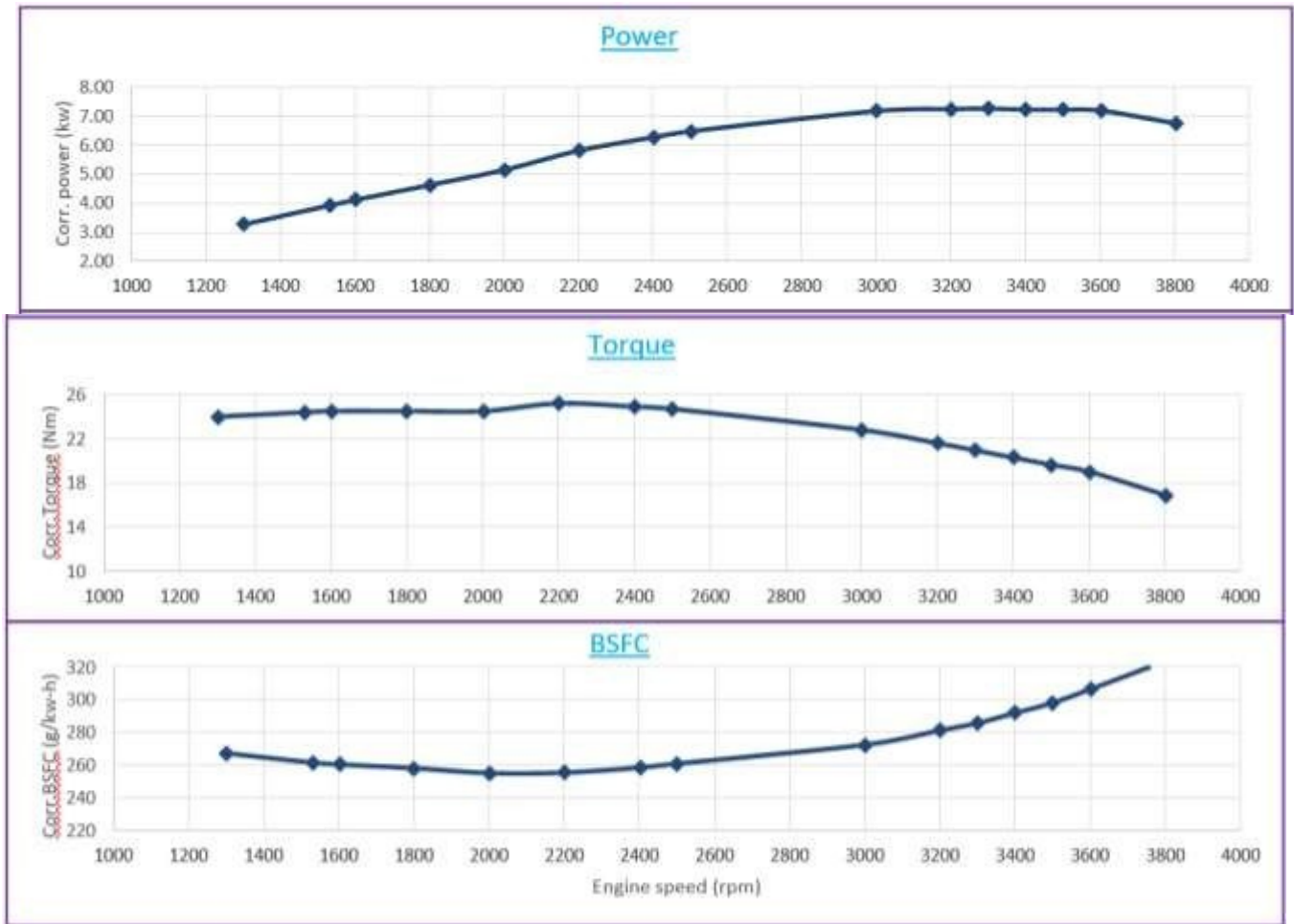

Figure 3 Performance Curve

B.2.5.4 Recommended Fuel, Lube Oil and Coolant details

Fuel Supply Details	
Fuel type	BSVI Bifuel-CNG + Petrol Use commercial CNG and Petrol
Electric Feed pump	Make: Pricol
Fuel filter	CNG Filter Make: Advantek Petrol Filter Make: Lub Oil filtration systems
Coolant Details	
Coolant	60% decalcified water - 40% anti-freeze Ethylene glycol coolant
Water pump	Suction type mounted on engine block, driven by 3pk belt

<p>Lube Oil Details</p>	<p>GEO 15W50 API SL & above grade</p> <p>Caution: - To avoid adverse effects on engine performance, do not use adulterated & adulterated engine oil.</p> <p>! Important: Use of oil other than our recommended oil will make our warranty null and void.</p>
-------------------------	---

B.2.5.5 Engine Lubrication Circuit

Engine lubrication circuit consists of the following parts:

1. Suction Pump
2. Lub Oil Pump
3. Spin on Filter
4. Main Bearing
5. Cam Shaft
6. Pressure Relief Valve
7. Piston
8. Rocker Arm Lubrication
9. Breather
10. Oil filling Pump
11. Oil Drain Pump
12. Needle Bearing
13. Oil Seal
14. Oil Vapour

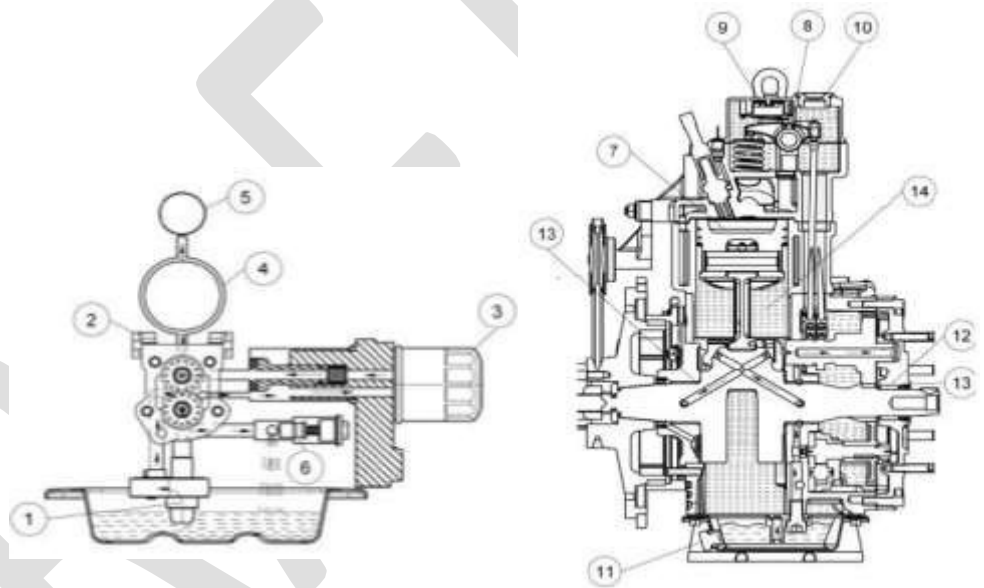

B.2.5.6 Coolant Circuit:

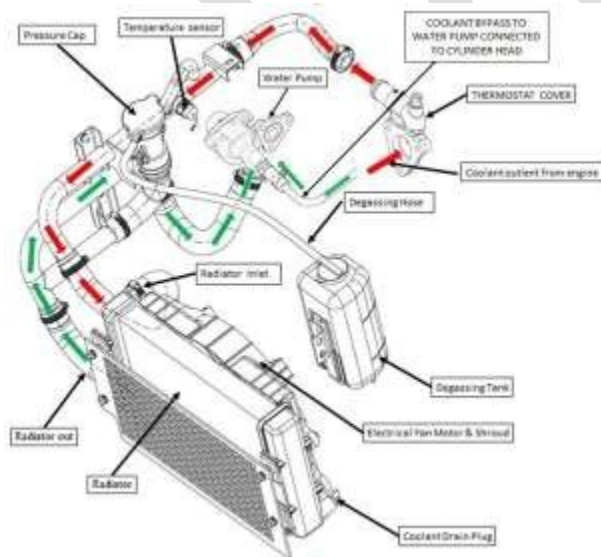

The cooling system consists of following components:

- | | |
|------------------------------------|--|
| 1) Radiator | 7) Degassing Hose |
| 2) Degassing Tank | 8) Radiator out and water pump inlet routing |
| 3) Electrical Fan Motor & Shroud | 9) Water Pump |
| 4) Hot coolant outlet routing | 10) Temperature sensor |
| 5) Radiator Inlet | 11) Pressure Cap |
| 6) Degassing Tank (Air vent Inlet) | 12) Coolant Drain Plug |

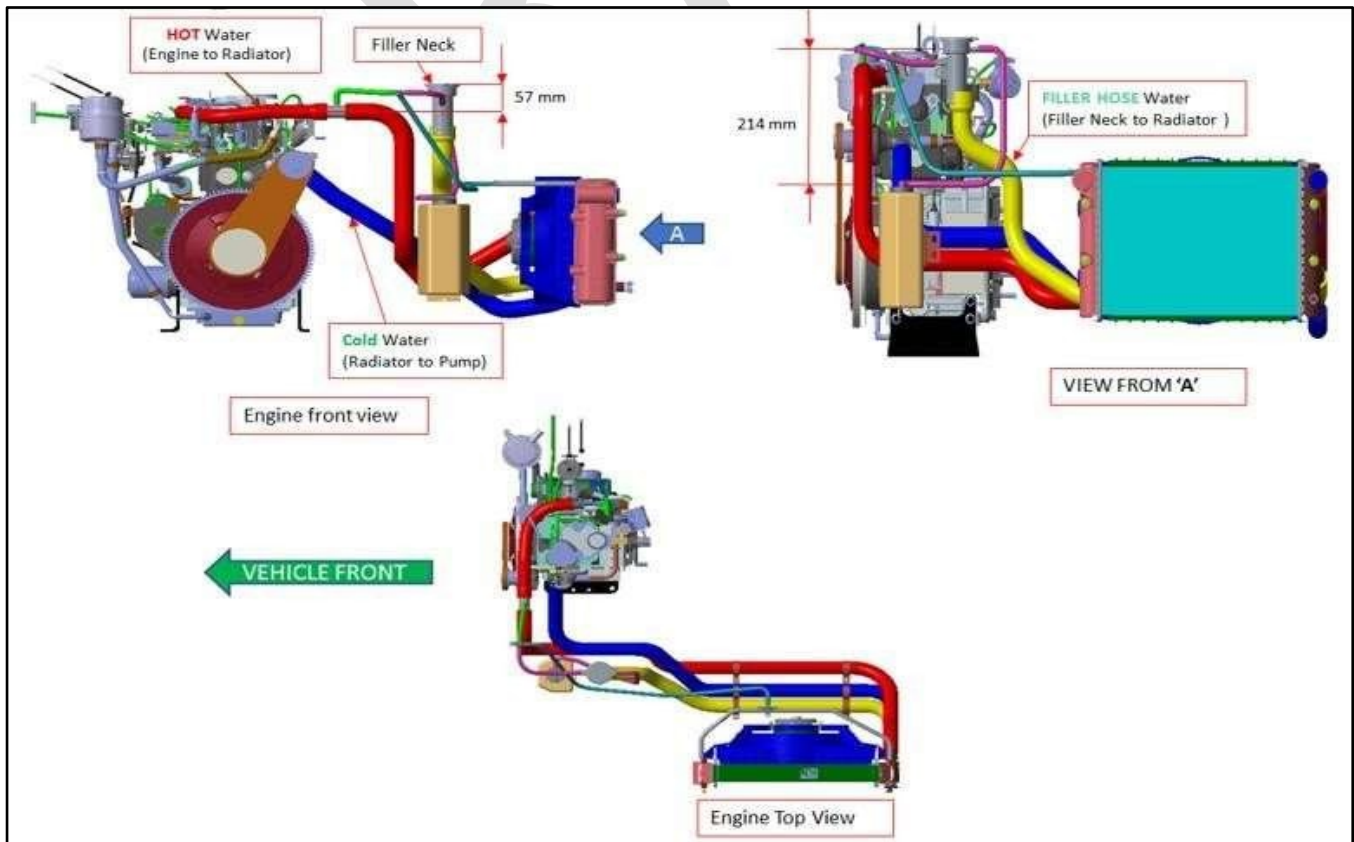

Figure 4 Engine Cooling System Layout

Function:

The cooling system quickly increases the temperature of a cold engine, removes excess heat from the engine and maintains constant engine operating temperature. Thermostat allows engine to heat up quickly which starts to open at temperature around 72° and fully opens at 80°. The 0.9bar pressure cap raises the boiling point of coolant up to 110deg

A 40:60 mixture of antifreeze and water protects the cooling system to sustain -5°C against freezing. Coolant is forced through the engine and other above mentioned system parts by the water pump. The radiator transfers engine coolant heat to outside air. Temperature sensor gives signal to ECU which controls Fan ON/OFF operation (84°C is ON and 78°C OFF). The fan draws air through the radiator. The degassing tank releases the entrapped air and gases from the coolant to improve the cooling performance.

B.2.5.7 Peripheral Components:

B.2.5.7.1 ECU

- ECU is a 32bits high performance micro-controller
- Contains Dataset (Information) which controls the working of the Engine across entire operating zones
- Fulfill IP67 protection level
- Voltage range: 9 ~ 16 V
- Tampering with or changing the info of the ECU is strictly prohibited & can lead to disqualification from the event

B.2.5.7.2 Starter Motor

- It is a BOSCH make 1 kW starter motor only for starting purpose.

B.2.5.7.3 CNG Injector

- It is driven by ECU to inject CNG in combustion chamber.

B.2.5.7.4 OMS System

- OMS system separates generated blow by mixture into Oil and Blow by gases. Oil is returned to crank case while blow by gases go to air intake hose

B.2.5.8 Engine Nomenclature

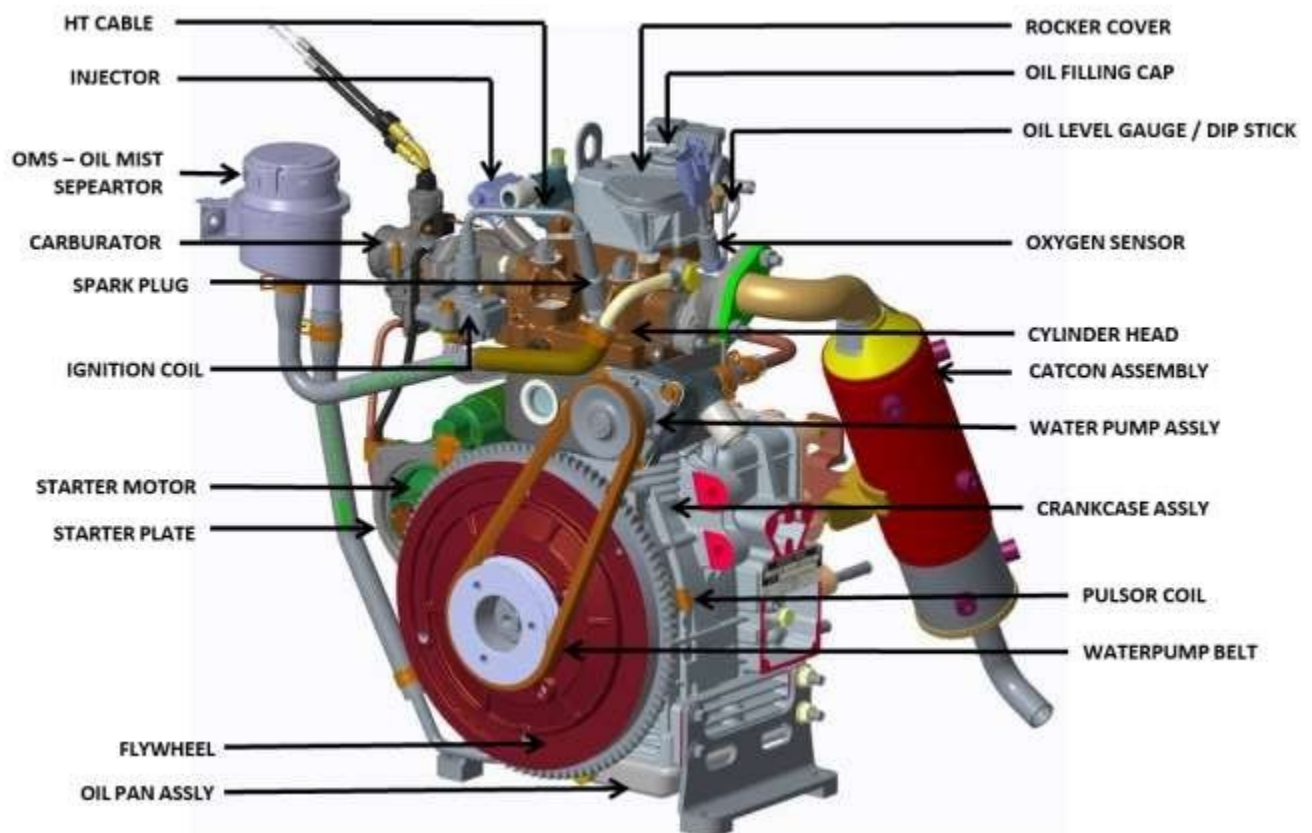

B.2.6 Sensor Layout on Bi-fuel CNG Engine

The most crucial sensors and their counterparts include:

- TMAP sensor
- Coolant Temperature Sensor
- Throttle Position Sensor
- Oxygen sensor
- CNG Filter
- Oil Pressure Switch
- Pulsar Coil
- FMA

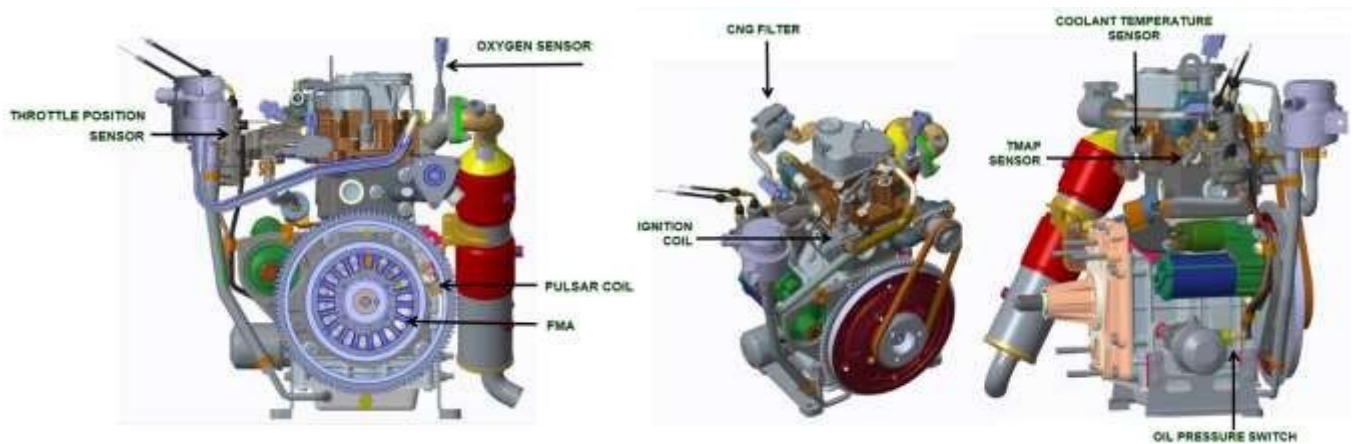

Figure 5 Sensor Layout

B.2.6.1 TMAP Sensor

It is used to measure the temperature and pressure of inlet manifold.



B.2.6.2 Oxygen Sensor

It is used to measure the air fuel mixture



B.2.6.3 Idle Control Valve

It is used to control the idling layer for Engine.



B.2.6.4 Ignition Coil

It converts low voltage to high voltage for the spark plug functioning.



B.2.6.5 CNG Injector

It is driven by ECU for injecting CNG into the intake manifold



B.2.6.6 CNG Filter with Sensor

Specifications are as mentioned below

- Working Pressure: 0.5 to 4.5 bar
- Filter Element: 10 microns



B.2.6.7 Carburetor with TPS

It is used to sense throttle opening as per demand by the driver

**CARBURATOR WITH TPS
 A03M200001**



B.2.6.8 Coolant Temperature sensor

It is used to monitor engine out coolant temperature



A03G100002

B.2.7 Engine Accessories

The accessories provided apart from earlier mentioned parts include :

1. Oil Filter ASM



2. Air Filter ASSY



3. ECU

ECU
A03G130002



4. Thermostat Valve

THERMOSTAT VALVE
A03G020007



5. Oil Mist Separation

OIL MIST SEPERATOR
A03A110001



It is introduced to remove oiltraces in exhaust gas

6. Hose- OMS to Crank Case.



7. Hose – Cylinder Head to OMS



8. Hose – Cylinder Head to Water Pump



B.2.8 Final Engine Layout on Vehicle

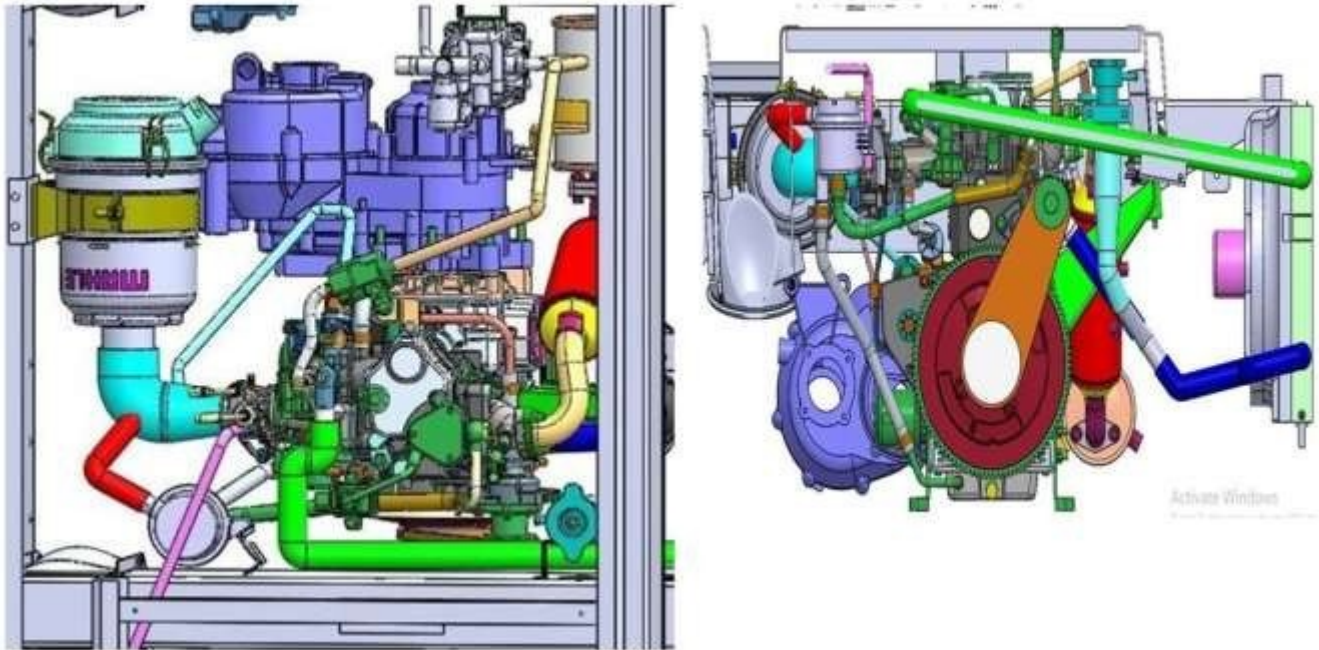

B.2.9 Dos & Don'ts:

Dos

- DO USE ONLY GENUINE GREAVES LIGHT ENGINES SPARE PARTS.
- DO Check lubricating oil level in Crankcase periodically and replenish, if necessary.
- DO Change lubricating oil in accordance with schedule for maintenance.
- DO Replace fuel filter and lubricating oil filter in accordance with schedule for maintenance
- DO Attend immediately to fuel, coolant and lubrication oil leaks.
- DO Attend the engine for any unusual sound and carry out necessary repairs.
- DO Quote engine number when ordering spare parts.
- DO Start the vehicle with choke and hold for 16 -20 seconds to maintain engine idle RPM in cold climatic conditions

DO NOT

- DO NOT neglect routine attention.
- DO NOT attempt to start the engine unless the fault detected is rectified.
- DO NOT allow the engine to idle for long periods.
- DO NOT use any but approved brands/grades of lub oils & coolant
- DO NOT load the engine beyond the rated output.
- DO NOT guess. Contact us for additional information.
- DO NOT operate the starter motor for more than 10 -15 seconds continuously.
- DO NOT increase the engine speed above 4000 rpm as the engine will misfire due to Spark Cut-Off

Note:

 The following is the part list which will be provided by Greaves Cotton along with the Engine.

Sl. No.	Part Description
1	Engine - Manifold to Manifold (without engine oil)
2	Flywheel Mounted Alternator
3	Starter Motor
4	Carburetor with TPS
5	Spark Plug/Ignition Coil/CNG Injector
6	TMAP/Crank & Coolant Temperature Sensor
7	Upstream Oxygen Sensor
8	OMS with breather in & Oil drain hose
9	Air Filter with Bracket
10	Idle Air control Valve and hose to intake manifold
11	Gasoline Fuel Pump
12	Gasoline Fuel Filter
13	Low Pressure Hose (filter to injector)
14	ECU
15	Fuel Rail Pressure & Temperature Sensor

 Further Details on the Engine & associated parts will be released on Website & BAJA SAEINDIA Forum

ARTICLE B.3: hCNG INJECTION KIT

B.3.1 hCNG System Layout

hCNG system comprises integration of components listed below:

- hCNG Cylinder
- Cylinder Tank Valve
- Filling Nozzle
- CNG Pressure Gauge
- Micro Switch
- High Pressure Regulator Assembly
- CNG Solenoid (Benzo with Tee Assy)
- hCNG filter
- Injector
- High Pressure Line (From Tank Valve to HPR)
- Low Pressure Line (HPR to Filter)

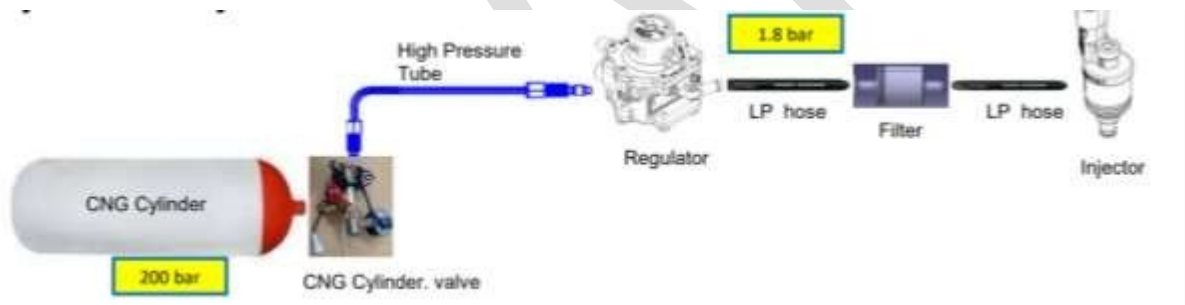

Figure 6 h CNG System Layout

B.3.1.1 hCNG Cylinder Tank Valve

The purpose of CNG filling valve is to control and regulate the flow of high-pressure natural gas from the station to the tank. These valves open and shut accordingly in response to the gas pressure under strict safety standards.

B.3.1.2 Key Benefits

- Rigid Mounting (Directly on the hCNG Cylinder- No additional Mounting Required)
- Brass- Material – Tightening Torque is 190 to 210 N-m
- Self-cleaning filter at inlet

- Child Parts Available- Repair Cost Reduction
- Integrated Pressure Gauge Tee, Manual Shut off, Filter (Single block construction)
- Contact Type Micro Switch

B.3.1.3 Do's and Don'ts

Do's:

- The cylinder valve is to be fitted by uniformly applying Teflon tape of IS: 3465 having a width of $\frac{3}{4}$ " and a minimum thickness of 40 microns for minimum of four and a half rounds.
- Screw the valve at first by hand, then, by using the special Minda Emer tightening Tool and a Torque Wrench, – Tightening Torque is 190 to 210 N-m
- It is forbidden to use (Pneumatic) flapping Torque Wrench or anything else that could damage the Valve Body.
- Periodical manual verification checks are required, to keep a log of results with date, time and identification code.
- While working on High Pressure Line, 1st Ensure the Cylinder Valve Shut off Knob is turned to Close.
- Before Loosening the "T" Gauge side 1st Ensure the Allen Key type Lock Screw must be removed.

Don'ts:

- Don't Loosen or Remove Pipes Without Ensuring Tank Valve Knob OFF
- Ensure that pressure is drained from the high-pressure line before attempting any tightening/loosening/any maintenance activity

B.3.1.4 Micro Switch

All vehicles are equipped with a micro switch which assures that vehicle goes-off and does not start during CNG fuel filling process.

- Ensure that the filling valve Dust Plug is properly inserted.
- Ensure that the Micro switch wires in the filling valve are connected properly.

B.3.1.5 Level Sensor

The CNG Level sensor is placed immediately after the first stage of reducer or after cylinder valve outside the tank. CNG cylinder, Cylinder Valve, first stage and level sensor are placed below the driver's seat.

The functions of the level sensor are as follows:

- Tank pressure sensor is mounted on the tank pressure gauge. It works based on potentiometer logic.
- It's an electrical component used to convert the pressure signal in the tank into an electrical signal approximately in the range from 1V to 5V.
- The CNG tank pressure gauge needle position changes based on the CNG tank pressure. The tank pressure sensor monitors the position of the needle and sends feedback to EMS ECU. EMS ECU interprets the tank gas pressure based on signal send by tank pressure sensor

- If CNG Pressure is max. (200-220 Bar) the Voltage value is less (0.33 to 0.25V) or vice-versa. It varies between 1V to 5 V.
- EMS ECU sends the fuel gauge Level & low fuel level feedback to instrument cluster to indicate fuel quantity in CNG tank.

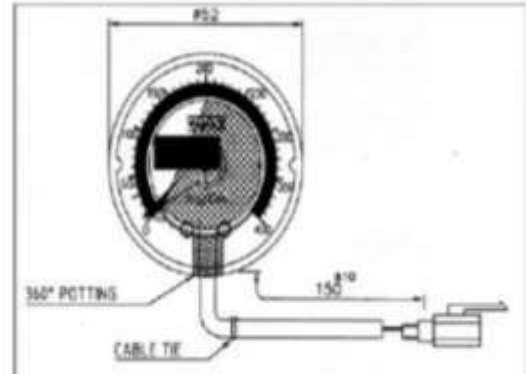

1. Mating Connector : Sumitomo/Besmak Part No. : 6187-3231 |
2. Use High Density Teflon Tape (PTFE) for proper sealing.
3. Three to four rounds of Teflon Tape (PTFE) to be wrapped in opposite direction of threads.
4. Sleeve material PVC.
5. Sleeve length 80mm approx.

B.3.1.6 hCNG Regulator

B.3.1.7 Performance Specifications

The specifications of hCNG regulator are as mentioned below:

- Inlet pressure range: 10-260 bar
- Flow rate up to 10 g/s
- Flow rate transient <0.3s
- Corrosion: 500 h
- Vibration: 5g
- Endurance Solenoid :250000 cycles
- Endurance Regulator: 600000 Cycles
- Approval R110-ISO15500 – AIS

B.3.1.8 Application

- Pressure regulator function is to accept high pressure CNG from the cylinder through Inlet and deliver low pressure regulated CNG through the outlet.
- It's a single stage regulator So its reducing pressure in single stage from 200 bar to 2.5 – 3 bar.
- To regulate pressure coming from Gas Cylinder
- Large Filter at inlet to increase the life of regulator. Filter can be replaced externally

- The regulator maintains specified outlet pressure (1.8 to 2.1 bar) at defined inlet pressure range and allows gas at set pressure to flow to engine with CNG Injector when solenoid is energized.

B.3.1.9 hCNG Solenoid Shut off Valve

Gas Solenoid electrically Energized, governs the fuel flow through the component. The activation of valve is setting up with specific strategies in ECU, gas solenoid or shut off valve is an electro-mechanical component in which a solenoid is excited to generate a magnetic field that it is used to move a shutter (plunger) to OPEN or CLOSE the gas flow through the valve to the injector

B.3.1.10 hCNG Low Pressure Filter

It Filters the Gas coming out from HPR and dampener to absorb the negative pulses coming back from Injector and Prevents injector from any debris, oil & moisture.

It is installed after the HPR and dampener to absorb the negative pulses coming back from injector

The specifications are as mentioned:

- Particulate Pre-Filter: 10 microns
- Sump Size: 15ml
- Fuel Rail Pressure Sensor packaged for sensing temp and pressure of gas before injection

B.3.1.11 High Pressure Line

CNG high-pressure pipe is a 6 mm (OD) steel pipe that carries CNG from the tank to the HPR Assy (High Pressure Regulator assy).

An essential safety precaution for working on pipelines is not to operate pipelines beyond their Maximum Operating Pressure

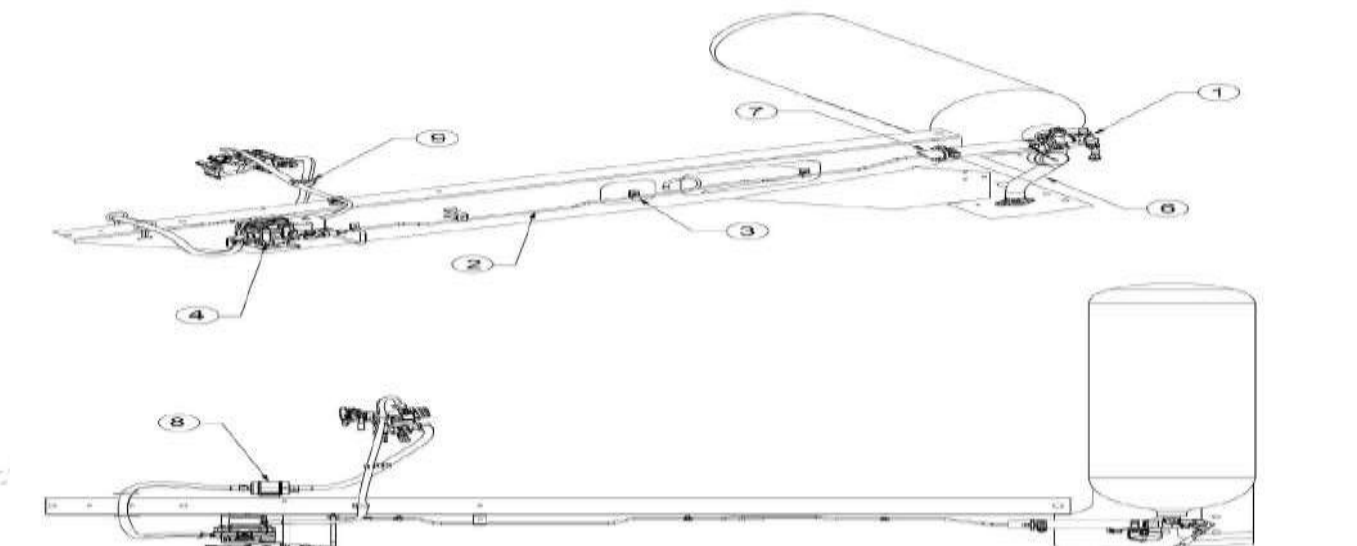

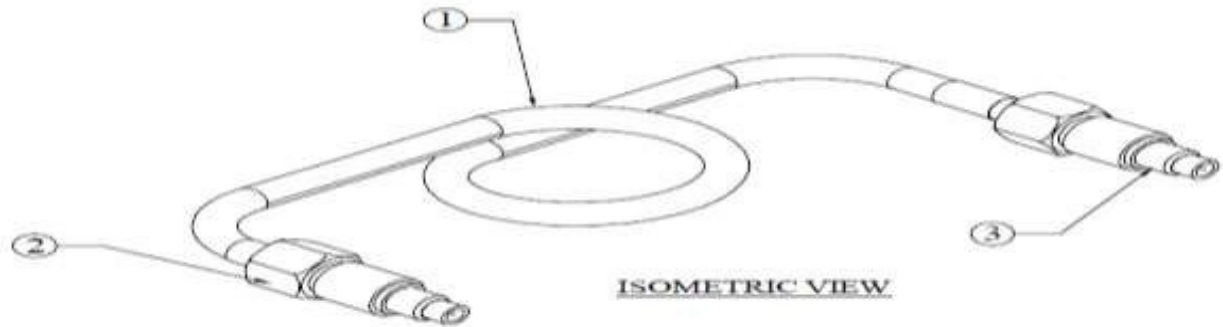

B.3.1.12 Cautions

- Part should not come in contact with mineral fluid during cleaning or any other process.
- Suitable protective cap for end ferrule nuts.
- H.P. pipe shall not have cracks or scratch marks.
- Both ends of tube shall be straight & burr free.
- SST 96 hours for white rust & 240 hours for red rust.
- H.P. tube homologation as per is 15716:2006.
- Pipe diameter: ID 4.0 mm & OD 6.0 mm.
- Torque for ferrule nut with mating part is 30 to 34 N-m.
- Ferrule & ferrule nut coating: Fe/Zn trivalent silver coating to resist corrosion.
- Expansion loops are used in piping systems to help with thermal displacement and thermal movement. If thermal movement reaches a value that is higher than expected, expansion loops can keep thermal displacement to a minimum and deflect stress from the piping system.
- Should more than one cylinder be installed, the piping between them must have a “loop” to absorb vibrations.
- Swagelok snoop solution to be used for Leakage checks instead of soap solution.
- Regular inspection. Get your CNG kit inspected and serviced every year by an authorized service facility.

B.3.1.13 Removal & Installation Tool hCNG Cylinder Valve Auto

- Only use Specified Tool for installation and Removal of hCNG Cylinder Valve

B.3.1.14 Important Points

- hCNG is Compressed Natural gas, mainly consist of Methane more than 95%.
- hCNG is filled in Kg not in Litre and the filling quantity depends on Pressure and Temp.

- hCNG Filling Pressure is maintained at 200-220 bar at Filling Station as a Standard in PAN India.
- 4. The filling estimated capacity depends on Ambient Temp and Pressure.
- 5. Only use Specified Tool for installation and Removal of hCNG Cylinder Valve.
- 6. Wrap minimum of four and a half rounds of Teflon tape (IS: 3465 having a width of 3/4" and a minimum thickness of 40 microns) in clockwise direction on threaded portion on cylinder Valve before tightening.
- 7. hCNG Cylinder Valve tightening torque is 190 to 210 N-m
- 8. hCheck Micro Switch for proper inserted of dust Plug if Engine does not crank just after filling the Gas.
- 9. Minor Leakage in LP line can be detected using i-SMART – Live data monitoring the R/P Value.
- 10. DTC- P0087 (Fuel Rail/system Pressure-Too low).
- 11. DTC –P0088 (Fuel Rail/system Pressure-Too high)
- 12. P0093 (Fuel System Leakage -Large Leakage) are for leakage in LP line.

B.3.1.15 Basic hCNG Practices

- Shut off all of the individual cylinder valves or disconnect cylinder electric solenoid valves.
- Start the engine and let it run until it stalls or shuts off.
- After a short while (about two minutes), try to restart the vehicle—which should not start. To verify that the cylinder valves have sealed in the closed position and have shut off the gas flow from the cylinders, repeat the attempt of restarting the vehicle until you are sure the engine will not start.
- If the engine will not run, the high-pressure fuel system should have very low pressure—less than 150 psi.
- To confirm this, check the high-pressure fuel gauge. It is essential to verify that the system has very low pressure before you proceed. Also, remember that only the section of the fuel system downstream of the closed cylinder valves are depressurized and can be safely disassembled.
- Use two wrenches to open a cylinder valve fitting slowly up to the point where gas just starts to flow out. Teams must stop at that point and wait until the entire gas drains out of H.P. line.

ARTICLE B.4: h CNG Vehicle Packaging & Overall Integration

B.4.1 Engine Mounting Concept

Engine Mounting refers to connecting it with chassis frame in order to minimize the vibration and noise level to the driver besides maintaining precise geometric positioning for sound integration.

There are two concepts for engine placements on chassis frame, as mentioned below

B.4.1.1 Engine Mounting from Bottom (Type 1)



AVM

Engine mtg. tray

Engine mtg. foot

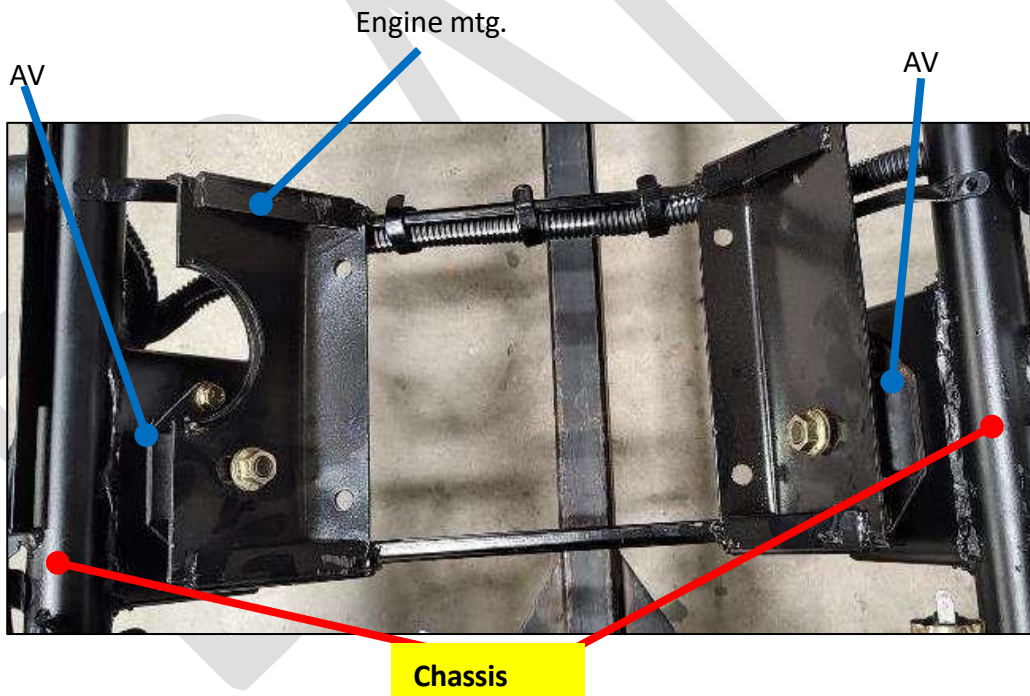
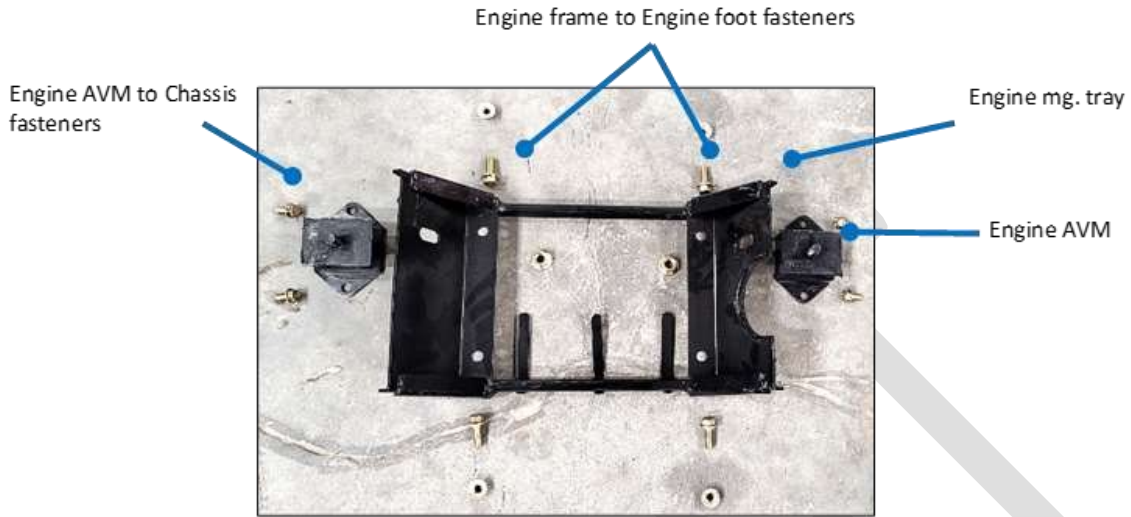

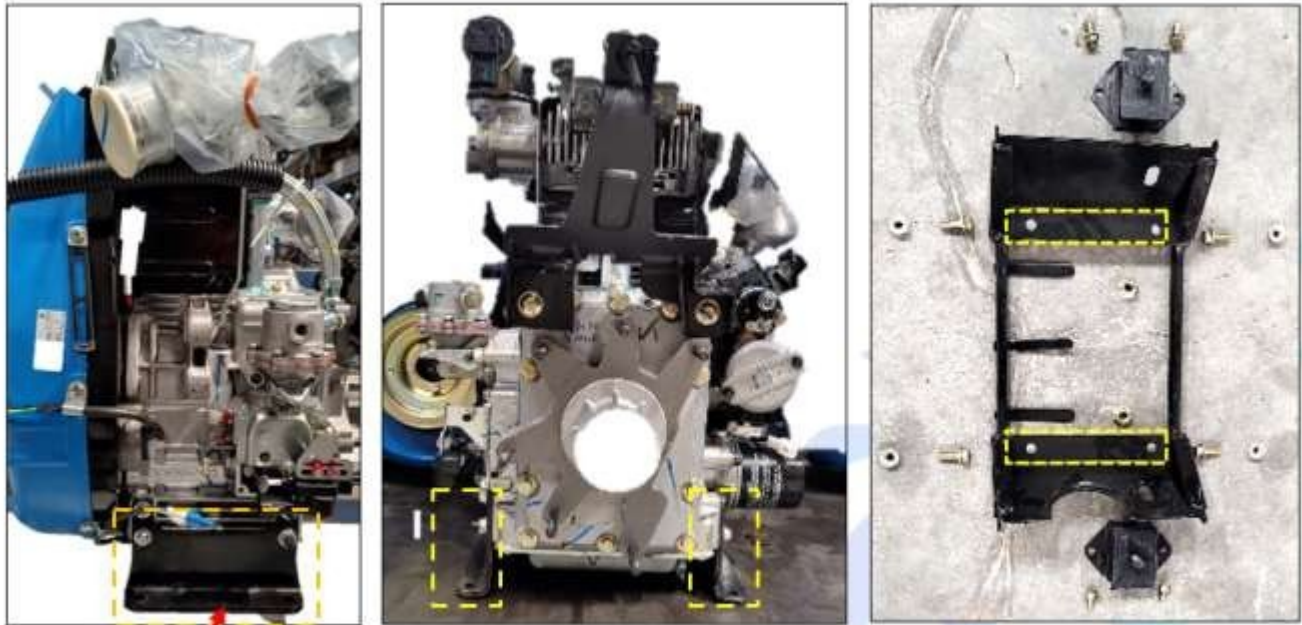

Engine foot

Fig. Engine foot assembly with Engine mtg tray

B.4.1.1.1 Do's and Don'ts

Do's:

- Always mount Engine Mtg. component on rigid and strong part of vehicle
- Stress free mounting of engine should be done i.e., mounting element should not be in stress condition due misalignment or any other factor
- Select anti-vibration elements such that minimum vibrations are transferred
- Fasteners should be tightened properly such that it doesn't loose by vibration
- Mounting in such way that gearbox shaft and engine shaft are aligned

Don'ts:

- Mounting engine very close to driver seating area
- Using low strength fasteners
- Selecting critical parts on engine for mounting

B.4.1.2 Engine Mounting from Both Side of Crank Case (Type 2)

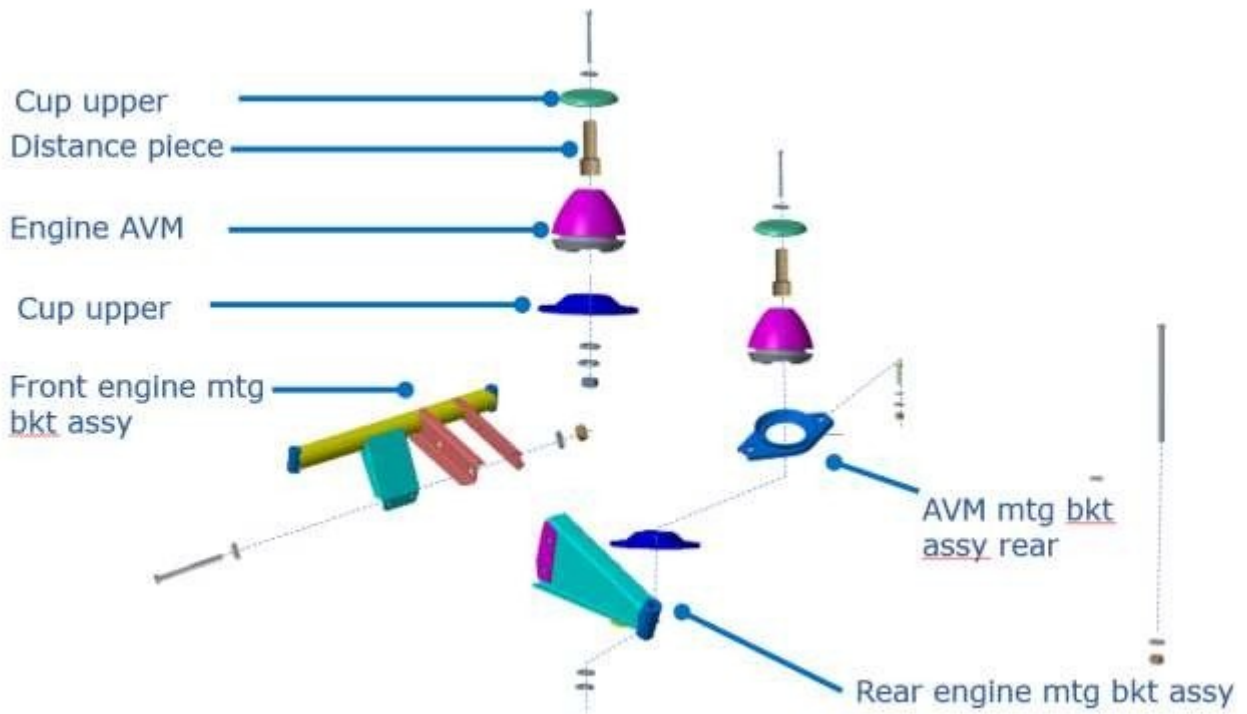
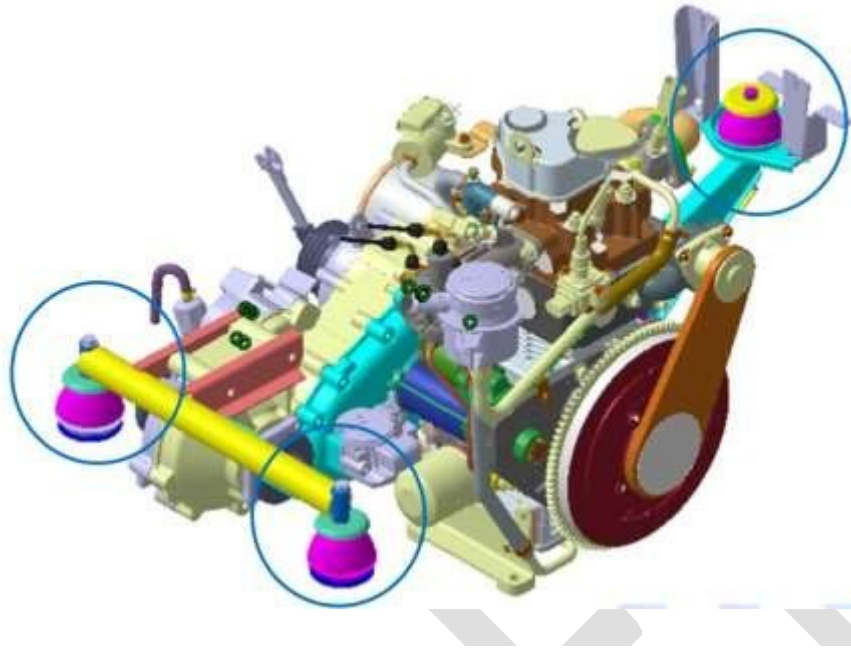

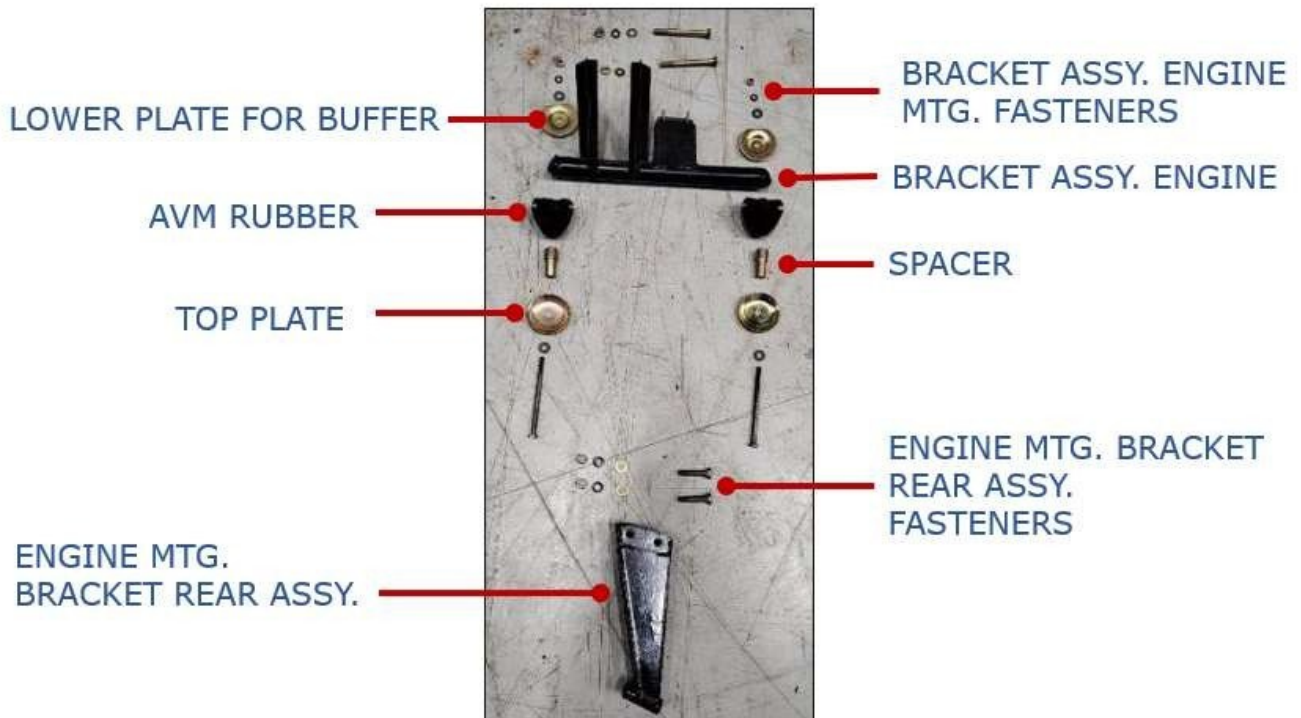
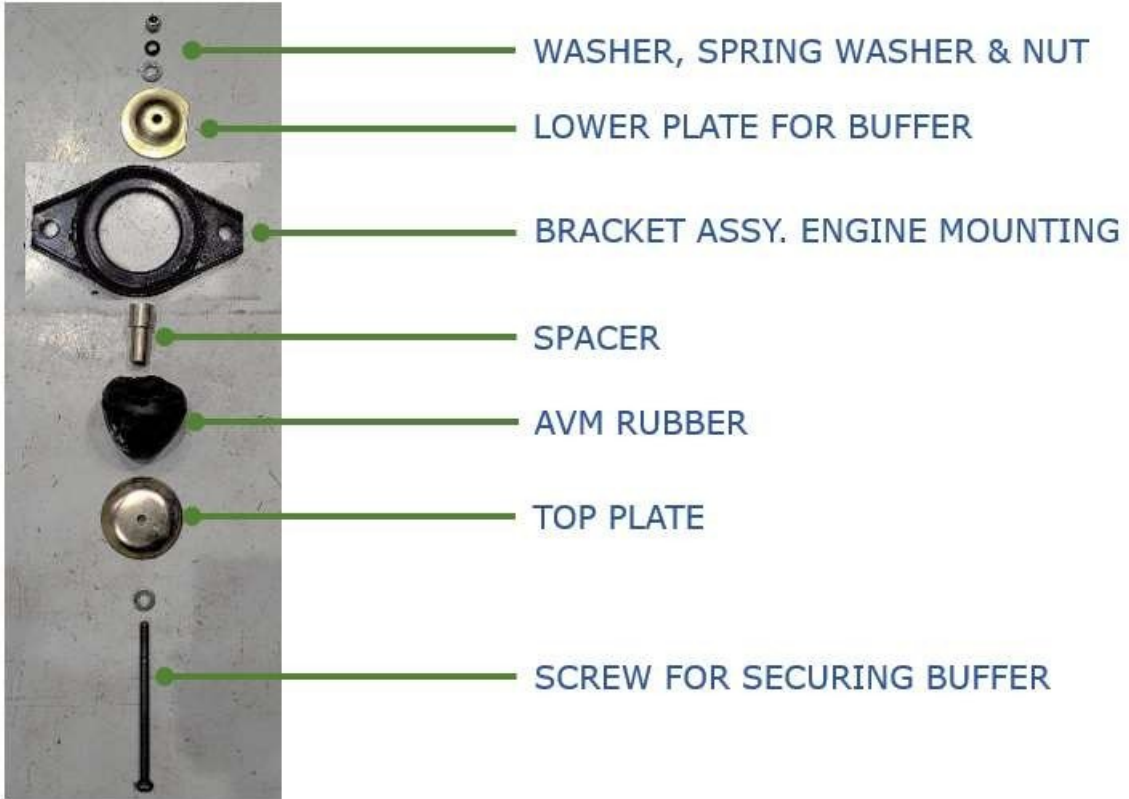

BRACKET ASSY. ENGINE – ENGINE MTG. FASTENERS



ENGINE MTG. BRACKET REAR ASSY.



BRACKET ASSY. ENGINE

ENGINE MTG. BRACKET REAR ASSY. FASTENERS

B.4.1.2.1 Do's and Don'ts

Do's:

- Always mount Engine Mtg. component on rigid and strong part of vehicle
- Stress free mounting of engine should be done i.e., mounting element should not be in stress condition due to misalignment or any other factor
- Select anti-vibration elements such that minimum vibrations are transferred
- Fasteners should be tightened properly such that it doesn't get loose due to vibrations
- Mounting in such a way that gearbox shaft and engine shaft are aligned

Don'ts:

- Mounting engine very close to driver seating area
- Using low strength fasteners
- Selecting critical parts on engine for mounting

B.4.2 Air Intake System

This assembly consists of following parts:

- Intake House
- Rubber Tube (PWM valve to Bellow)
- Bellow (Air filter to Engine)
- Rubber Tube (OMS to Bellow)

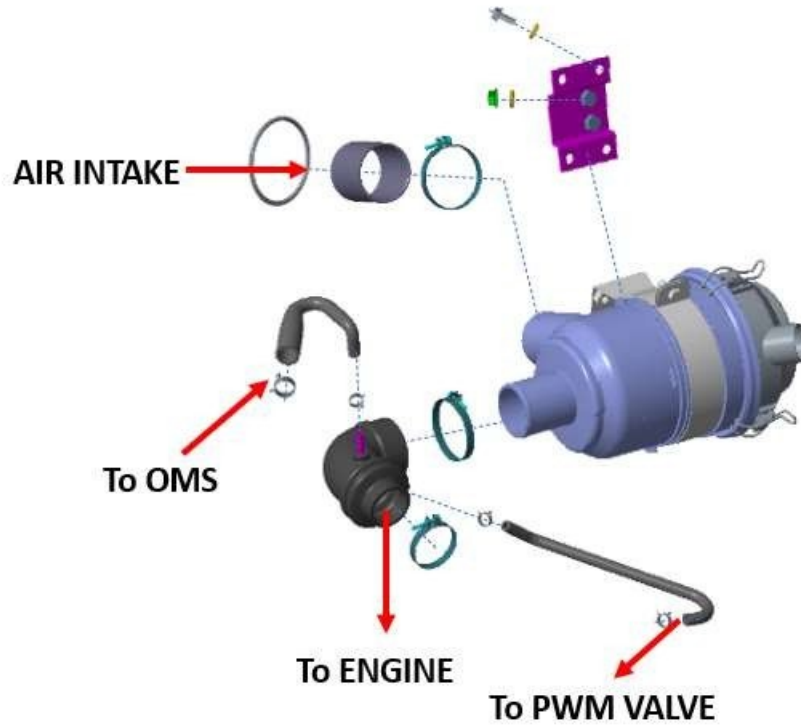

B.4.2.1 Do's and Don'ts

Do's:

- Select location of air filter where minimum dust and water can be reached
- Proper tighten of bellow clamp
- Dust ejector valve position in downward direction

Don'ts

- Loose or torn bellow assembled on air filter
- Use any other size of bellows and hoses

B.4.3 Exhaust System

B.4.3.1 Exhaust System Location

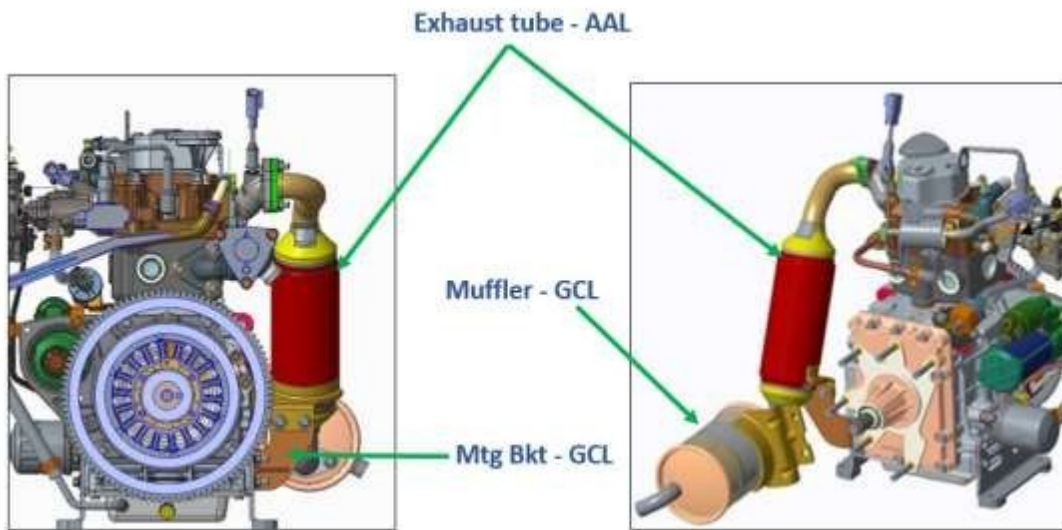

B.4.3.2 Exhaust System Fasteners and Torque

SR. NO.	DESCRIPTION	DRAWING NO.	NO. OFF	TORQUE Nm
1	SPRING WASHER	1-7565-07	2	
2	HEX. FLANGE NUT M8X1.25	075-028-10	2	25 (AT LOCATION E)
3	HEX. NUT M8X1.25	500-002-25	2	25 (AT LOCATION A)
4	HEX. FLANGE SCREW M8X1.25X20	500-028-05	2	25 (AT LOCATION B)
5	01b150081	01B150081	2	25 (AT LOCATION C)
6	MUFFLER ASSEMBLY	A03A070010	1	
7	CATCON ASSEMBLY	A03A070011	1	
8	SUPPORT BRACKET FOR CATCON	A03A070013	1	
9	GASKET (EXHAUST MANIFOLD)	A03S210001	1	

B.4.3.3 Exhaust System Assembly

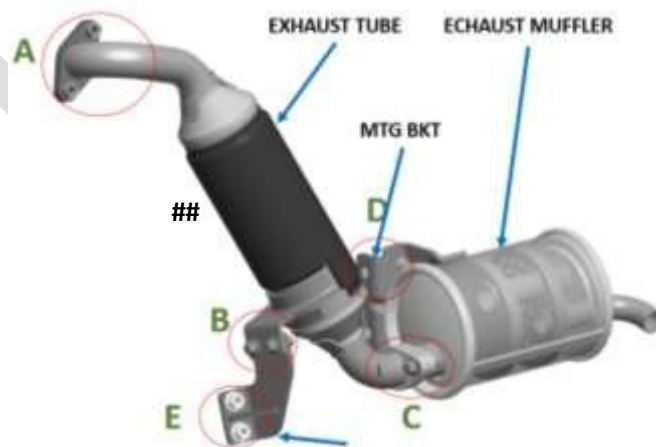

- CatCon Assembly in the above image is only for representation purposes, In actual Engine will be fitted

with Exhaust Pipe Tube only. Teams who wish participate in Go Green, can install their own after treatment device.

B.4.3.4 Do's and Don'ts

Do's:

- Use gaskets between mating parts
- Direction of components installed as specified
- Checks for any leakage from joints and mating parts

Don'ts:

- Use fasteners with nylon material
- Assemble mating parts in stress condition
- Locating very near to driver seating area, fuel system or cooling system

B.4.4 Cooling System

The cooling system is a combination of several parts as mentioned below:

- Tee joint (radiator)
- Fuel pipe (t joint to carburetor)
- Hose clamp diameter 45mm
- Hose pipe (tube to radiator)
- Hose pipe (radiator to engine)
- Hose pipe (engine outlet to tube)
- Filling hose
- Rubber tube rh (tee joint to radiator)
- Hose pipe (assembly tube hot flow - t connect)
- Frame assembly radiator mtg (small)
- Radiator & fan assembly
- Coolant recovery tank
- Remote filler neck assembly
- Rubber tube (t joint to small radiator)

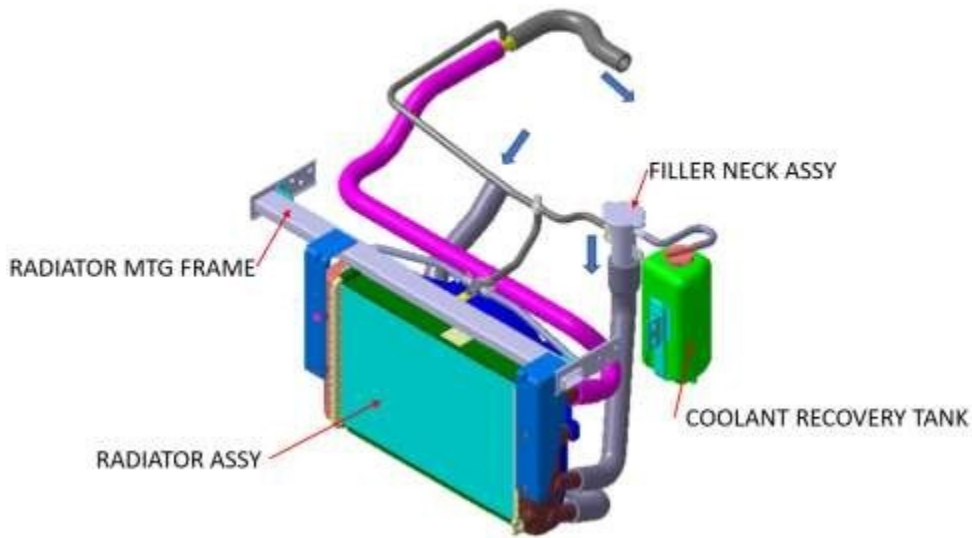

General Schematic Overview of the Cooling System

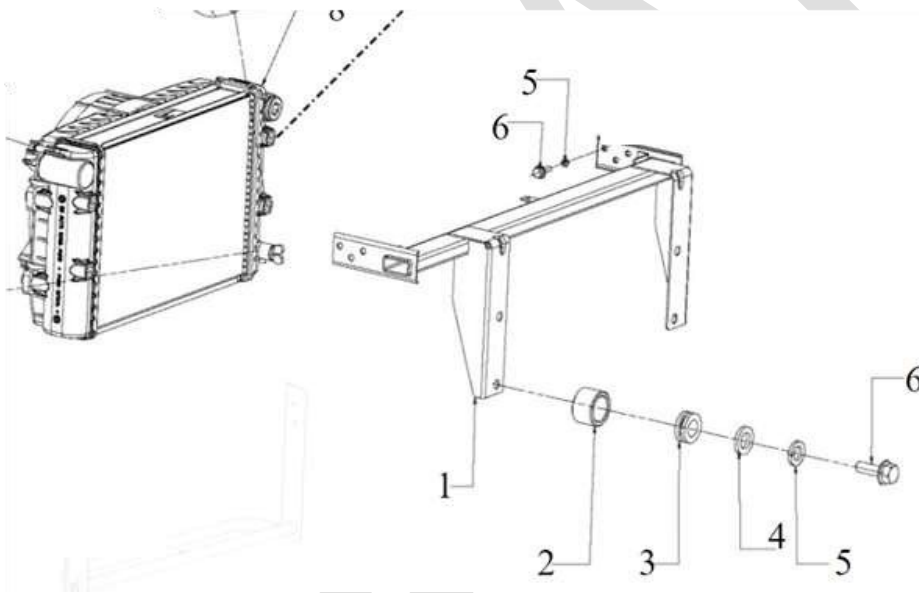

Schematic Overview of the Cooling System

- | | |
|-------------|---------------------------------|
| 1. 37150049 | FRAME ASSY RADIATOR MTG (SMALL) |
| 2. 27010622 | BUSH (FUEL TANK MTG) |
| 3. 27010621 | GROMMET (FUEL TANK MTG) |
| 4. 73060064 | PLAIN WASHER M6 |
| 5. 81020064 | SPRING WASHER M6 |
| 6. 80477295 | HEX HEAD FLANGED SCREW M6x18 |

B.4.4.1 Cooling Hoses

The specifications required for the coolant hoses are as mentioned below

- Material: EPDM BRAIDED type
- Minimum wall thickness: 5mm
- Operating temperature range: -40 °C to 125 °C
- Burst pressure: 1.4 bar minimum
- Shore Hardness: 60 ± 5 'A'

B.4.4.2 Radiator Specifications

The radiator holds these attributes:

- Air flow rate – 3.2 to 3.5 m/sec
- Water flow – 22 LPM
- Coolant – Ethylene glycol based + DI Water
- Heat dissipation – 6500 ± 10% kcal/hr
- Water holding capacity – 1 ± 0.3 Ltr
- Dry weight – 3.8 kg Approx.

B.4.4.3 Do's and Don'ts

Do's:

- Use coolant grade and mixing proportion as specified
- Bleeding of system after adding coolant mix
- Check for any leakages from joints
- Coolant level to be maintained in recovery tank
- Keep fins of radiator clean

Don'ts:

- Open pressure cap in hot condition
- Use hoses with other material than specified

B.4.5 Fuel System (Petrol)

The fuel system is an integration of several parts as mentioned below:

1. Fuel Pipe: Material – NBR, PVC & SCM

- Fuel Pipe (Fuel Tank to Fuel Cock)
- Fuel Pipe (Pump to T joint)
- Fuel Pipe (T Connector to Carburettor)

2. Fuel Tank: Capacity - 3 Litre

- Fuel Tank Assy (CNG)
- Solvent Tank Cap

- Location should not be above the Exhaust System of the Engine in any case.

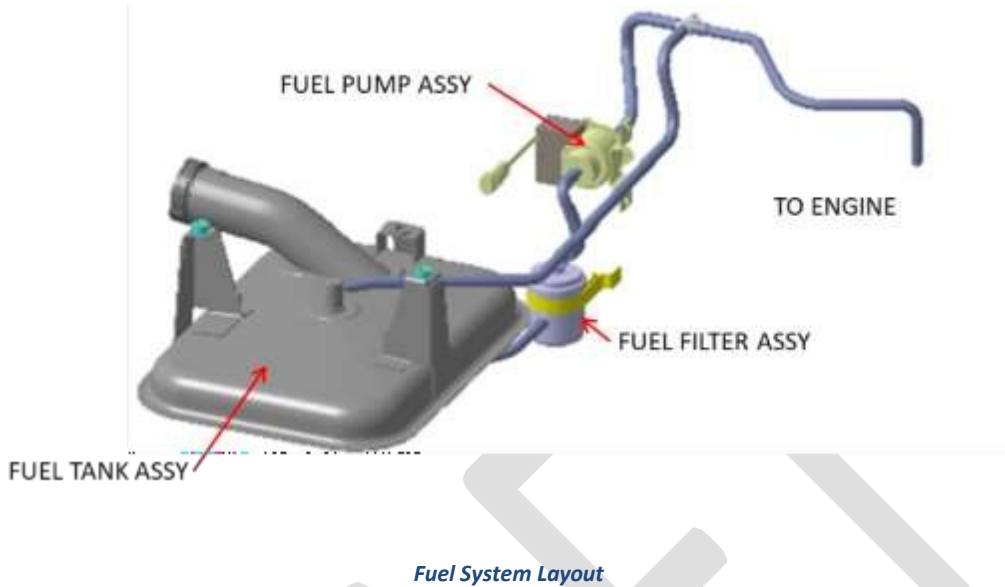

Thus, the fuel flow in the Fuel system should correlate the Fuel Flow Chart:

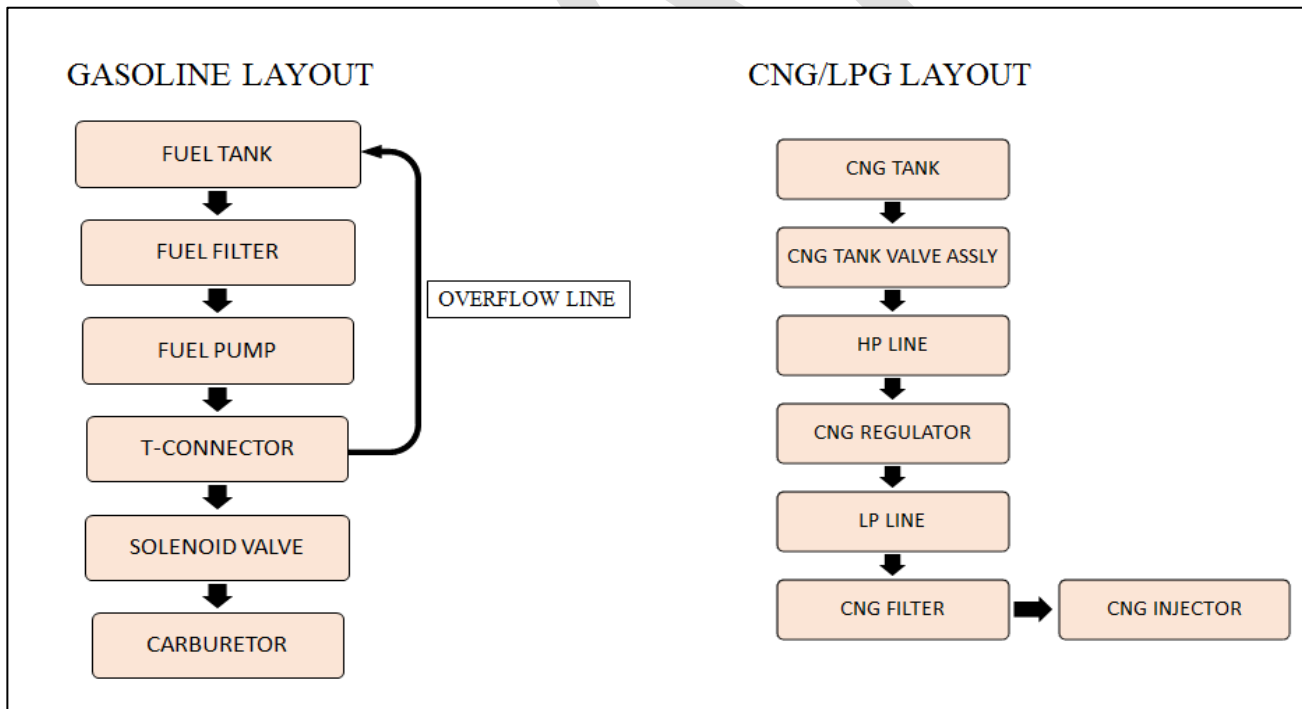

Figure 7 Fuel Flow Chart

B.4.5.1 Caution

It should be ensured that

- The fuel line should never be blocked

- Rubber pipe joints be properly clamped so as to prevent leakage
- Fuel filter arrow direction is followed while fitment
- Fuel line routing is away from any sharp edge, moving parts and hot parts

B.4.6 Electrical System

Electrical systems incorporate several functional components which form the foundation for standard utility provision.

- Wiring Harness (Front & Rear) Panel [Box]
- Engine Compartment Relay Panel [Box]
- Driver Cabin Fuse Panel [Box]

Sound engineering practices must be implemented for designing the harness layout and installing it.

- W/H should be fixed away from direct heating of engine and exhaust system
- Location of W/H must ensure less vibration and isolation (sufficient distance) from moving parts
- +ve cables of W/H should be routed properly in order to prevent short circuit
- Component specific coupler must be used to prevent the respective component or W/H from getting damaged
- Battery voltage should be maintained at 12V or above
- Petroleum jelly must be applied on battery terminal for preventing oxidation
- Grounding or –ve connection of system should be done properly on bare metal. Connection on painted surface must be avoided
- Harness should not loosely hang, it should be routed properly. for example, as Shown in image it is clamped with the help of rubber coated metal clip & cable tie.

Figure 8 Wiring Harness Practices



B.4.6.2 Fuel Changeover Switch

Fuel mode selector switch will assist in selection of fuel mode (GAS or PETROL)

B.4.6.2.1 Specification

- Type: 3 Position / Rocker
- Voltage: 12 V DC
- Current rating: 4 Amps
- Operating temp: -30 °C to +85 °C

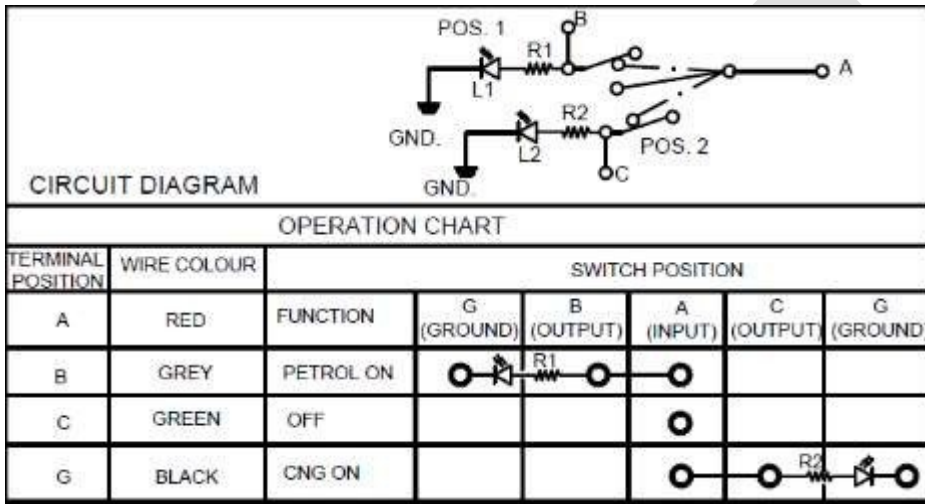

Figure 10 Circuit Diagram



Figure 9 Fuel Mode Selector Switch

Note : Teams must always run their vehicle in Gasoline Mode during testing/validation at their end, unless it is running for a specific event(at Event Site).

B.4.6.3 Vehicle Speed Sensor



Figure 10 Vehicle Speed Sensor

TECHNICAL SPECIFICATIONS :

- 1) PULSE / REV = 8 PULSE
- 2) Vcc = 8-27V DC
- 3) SIGNAL OUTPUT = SQUARE WAVE (0 to Vcc)
- 4) DUTY CYCLE = 40% - 60%
- 5) PULL UP INSIDE SENSOR = 5K
- 6) OPERATING TEMP. = -20°C TO 100°C
- 7) CABLES SHOULD COMPLY ISO 6722
- 8) TEMPERATURE/HUMIDITY (DAMP HEAT) CYCLING TEST – AS PER IS 9000 PART 14 / SEC 2
- 9) VIBRATION TEST – AS PER IS 9000 PART 8
- 10) CORROSION RESISTANCE (SALT SPRAY) TEST – AS PER IS 9521-1980
- 11) TESTS TO BE DONE AS PER DVP

Figure 11 Vehicle Speed Sensor Specification

B.4.6.4 Clutch Switch

A clutch switch is an important component used for Starter motor protection.

B.4.6.4.1 Specification

- Switch type: Normally closed contact

- Total plunger travel: 3.8mm
- Contact off at 1.2mm of plunger travel
- Switch load 12V DC, 250mA Max
- Operating temp: -30 °C to 85 °C
- Tightening torque: 7.0 Nm



Figure 12 Clutch Switch with Circuit Diagram

ARTICLE B.5: h CNG CYLINDER

The Specs of the cylinder recommended but not limited to the teams are as follows:

- OD : 139.7 mm
- Water Capacity : 4.8 Ltr
- Approx Length : 455 mm
- Working Pressure : 204 kgf/cm² at 15 degC
- Burst/Test Pressure : 340 kgf/cm²

Teams can decide on their what type & specs of cylinder they need to buy. Further Teams are advised to procure Type 3/Type 4 Cylinder, details of which will be communicated on BAJA SAEINDIA Forum Shortly.

ARTICLE B.6: Safety & Homologation Requirement-

It is mandatory to adhere to the requirements of safety as laid down in AIS 028 standard for a CNG vehicle. The components, layout, construction, and connections alongside necessary minimum clearances will be strictly scrutinized against the requirements laid down in AIS 028.

1. For description of components/definitions please refer to AIS 028 Section 1.1 to 1.4
2. For cylinder requirements refer to AIS 028 section 2.0, however section particularly referring to LNG need not be considered for CNG application.
3. Section 3.0 covers the requirements to be satisfied for the selection and installation of fuel lines (both high pressure and low pressure)
4. For the system used requirements as per section 4.0 for gaseous fuel control equipment must be strictly adhered to.
5. Identification label is recommended. (As per required for bi-fuel vehicle as per AIS 028 section 6)
6. Section 7.0 is for (kit) installer. It is important to double check and confirm that the installation has adhered to the requirements as per AIS 028. It is necessary to ensure that the installation is completely leak-proof.

7. For repair and scrapping please refer to section 8.0 of AIS 028.

Each team must have one person as a safety commissioner who will evaluate the vehicle against all the requirements in the AIS 028 standard. She/He will be responsible for safety and will present to the jury their understanding of the standard and will present the details of how they have ensured adherence.

It will be each team (Particularly the safety commissioners) responsibility to collect and maintain the statutory approval certificate of the cylinders, the kit components, and the wiring harness from respective parties for inspection.

ARTICLE B.7: h CNG Refilling:

- hCNG for the teams's vehicle will be filled via a cascade system available at event site.
- hCNG Tank Valve will be used for filling the CNG gas in the Buggy.



CNG Valve



CNG Gas Filling Nozzle

ARTICLE B.3: ROLL CAGE

B.3.1 Objective

The purpose of the roll cage is to maintain a minimum space surrounding the driver. The cage must be designed and fabricated to prevent any failure of the cage's integrity during normal operation or a collision or rollover.

 **Teams must build a new roll cage every year, teams using roll cage from previous competitions will not be allowed for the main event. The roll cage MUST have a unique signature on the RRH member of the roll cage, refer to Figure B-3.**

Roll cage signature to be in the following format

TEAM ID / SEASON YEAR / CAR NUMBER (THREE DIGIT)

For example, team XYZ with Team ID 25161, car number 87 participating in BAJA SAEINDIA 2023 has the roll cage signature as,

25161 / 2025 / 087

Teams may reuse TYRES, shock absorbers/fox suspension, CVT, and driver's seat for a maximum period of three years. However, for every event, the original invoice needs to be showcased to the TEJ team at the competition site.

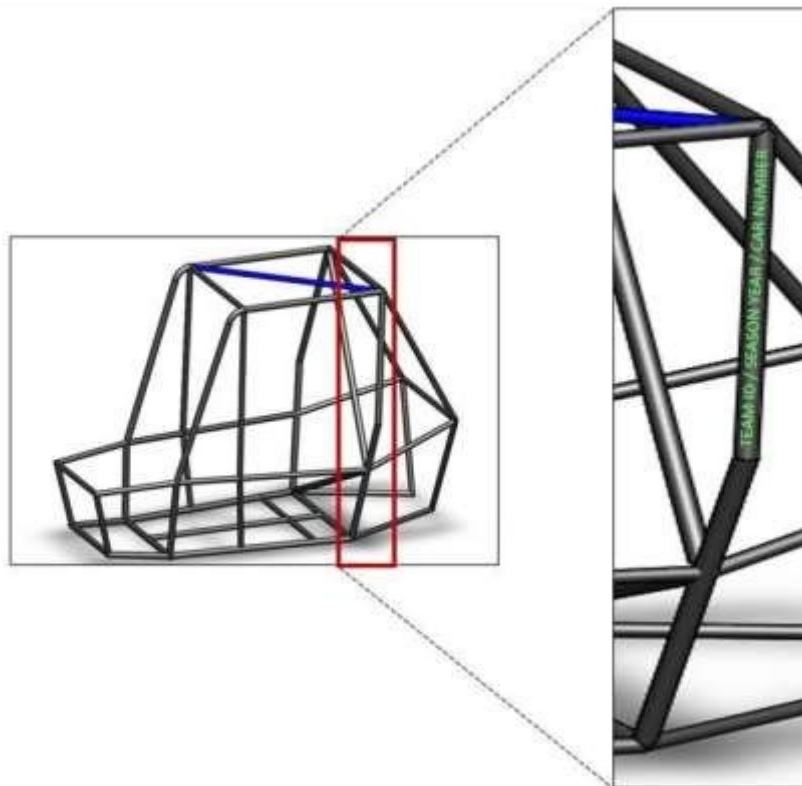

Figure B- 3: Roll Cage Signature

The signature on the roll cage is to be stamped using a 6 mm (0.25 inch) sized number punch. Refer to Figure B-4 for a tool that can be used for stamping.



Figure B- 4: Tool to be used for Roll cage Signature

B.3.2 Roll Cage Structure

The roll cage must be a space frame of tubular steel. The following section outlines the requirements of the physical members and joining methods of the roll cage. Roll cage and Frame Members must be fully welded, and welds must not be ground, sanded, or modified to prevent inspection. Roll Cage Members that are bent must not exhibit any wrinkles, kinks, or any detrimental deformation to the cross-section. The terminology used in the rule book relating to the roll cage structure is given below.

- **Frame:** The entire tubular structure including all non-cantilevered tubes.
- **Roll Cage:** Primary and Secondary Members are used to protect the driver.
- **Member:** A Primary or Secondary required element beginning and ending at Named Points.
- **Named Point:** The intersection of the centerlines of two or more joining members.

B.3.2.1 Member Requirements

Roll cage members must be made of steel tubes and may be straight or bent. Straight members may not extend longer than 1016 mm (40 in.) between Named Points or comply with Rule B.3.2.4 - Additional Support Members. Bent members may not have a bend greater than 30 deg. that does not occur at a Named Point, and may not extend longer than 838 mm (33 in.) between Named Points or comply with Rule B.3.2.4 - Additional Support Members. Small bend radii (<152 mm or 6 in.) that terminate at Named Points are expected and are not considered to make a member bent, regardless of angle. A bend that terminates at a Named Point implies the point lies at or between the points of tangency of the bend. Required dimensions between roll cage members are defined by measurements between member centrelines, except where noted. Junctions of Primary and Secondary members described below must be within 51 mm (2.0 in) of the Named Point, except where noted.

Mitered tubing joints of greater than 5 deg. will be treated as bends. Miters of less than 5 deg. will be treated as butt joints and subject to Rule B.3.2.14 - Butt Joints. Required members constructed of multiple members, such as the SIM and LFS, will be judged as continuous members from Named Point to Named Point, except where noted.

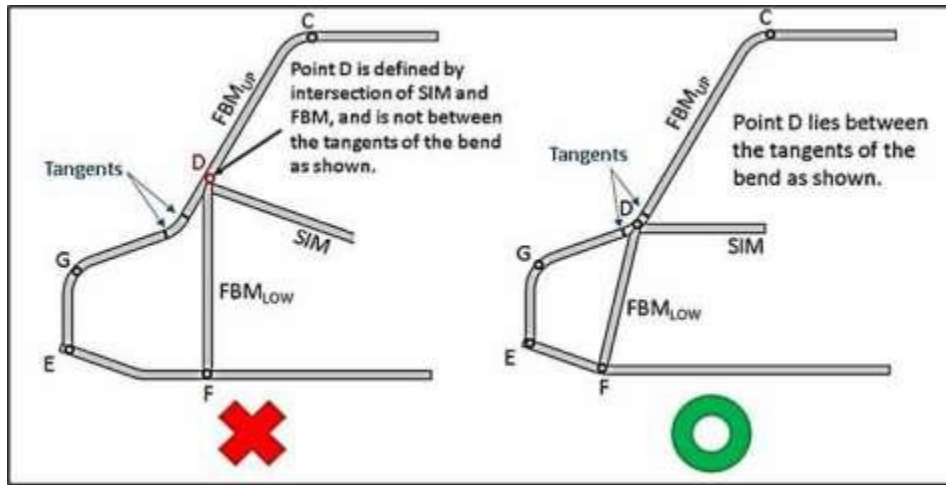

Figure B- 5: Roll Cage, Bend and Member Termination

B.3.2.2 Primary Members

The roll cage must be a space frame of tubular steel. The required members of the roll cage are illustrated in Figure B-6. Primary members must conform to B.3.2.16 - Roll Cage Materials.

Primary members are: -

- RRH Rear Roll Hoop
- RHO Roll Hoop Overhead Members
- FBM Front Bracing Members
- ALC Aft Lateral Cross Member
- BLC Overhead Lateral Cross Member
- CLC Upper Lateral Cross Member
- DLC SIM Lateral Cross Member
- FLC Front Lateral Cross Member
- LFS Lower Frame Side Members

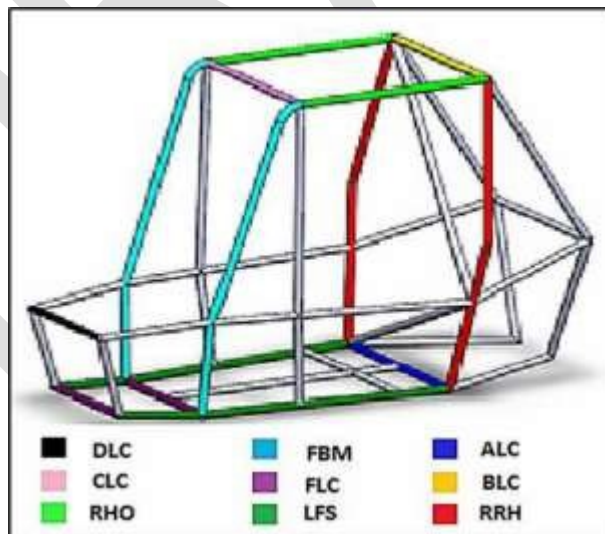

Figure B- 6: Roll Cage, Primary Members

B.3.2.3 Secondary Members

Secondary members must be steel tubes having a minimum wall thickness of 0.89 mm (0.035 in) and a minimum outside diameter of 25.4 mm (1.0 in) or rectangular steel tubes having a minimum wall thickness of 0.89mm (0.035 in) and a minimum outside dimension of 25.4 mm (1.0 in).

- LDB Lateral Diagonal Bracing
- SIM Side Impact Members
- FAB Fore/Aft Bracing Members
- USM Under Seat Member
- RLC Rear Lateral Cross Member
- Any tube that is used to mount the safety belts or fuel tank or protect the fuel system.

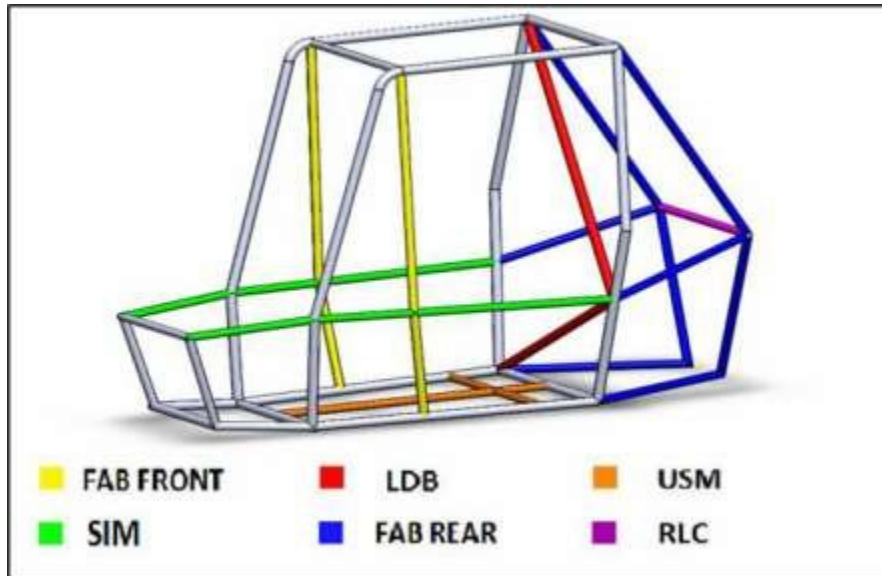

Figure B- 7: Roll Cage, Secondary Members

- ☑ **The ends of the ALC member should be extended and left open for measurement purposes of the pipe cross-section.**
- ☑ **Any one member in the engine compartment area should also be left open for the same purpose.**
- ☑ **Colour coding is given only for a better understanding of the design and not to be related to primary and secondary members.**

B.3.2.4 Additional Support Members

For bent or straight Primary Roll Cage Members that exceed the maximum allowable length, additional support members may be added. For straight members, a single secondary member should connect from the mid-point (+/- 127 mm or 5 in.) to a Named Point. For bent members, a single secondary member should connect from between the tangents of the bend to a Named Point. If Additional Support Members are used, the supported Roll Cage Member will be evaluated for length and/or additional bends between the Named Point and the location of the Additional Support Member. At no time may a bent member have a bend greater than 30°.

For bent or straight Secondary Roll Cage Members that exceed the maximum allowable length or bend angle, additional support members may be added. For members that exceed only the allowable length OR the allowable bend angle a single additional support member is required as described below. For members that exceed both the length AND bend angle limits, two additional support members are required as described below.

Named Roll Cage Points: A, B, C, D, F, S, (E and/or G for 'Nose' cars) and P, Q, and R as applicable for FAB systems. All named points are implied to have a Left and Right-hand side, denoted by subscript L or R (e.g., AL and AR) as shown in Figure B-8 and Figure B-9.

Length \ Bend angle	$\leq 838\text{mm}(33\text{in})$	$> 838\text{mm}(33\text{in})$ & $\leq 1016\text{mm}(40\text{in})$	$> 1016\text{mm}(40\text{in})$
0°	✓	✓	1 support member required*
$\leq 30^\circ$	✓	1 support member required*	2 support members required***
$> 30^\circ$	1 support member required**	2 support members required***	Not allowed

*Required within 51mm (2in) of the midpoint of the overall tube length
 **Required within the tangents of the bend
 ***One required within 51mm (2in) of the midpoint of the overall tube length and second within the tangents of the bend

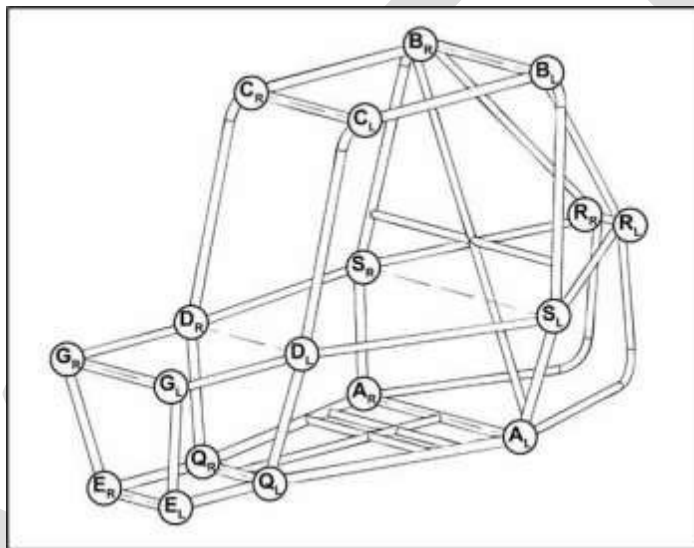

Figure B- 8: Roll Cage, Named Roll Cage Points, Rear Braced Frame.

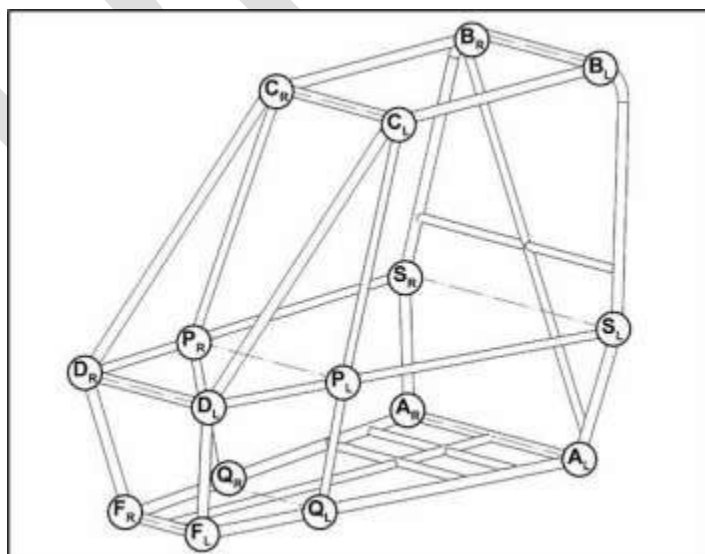

Figure B- 9: Roll Cage, Named Roll Cage Points, Front Braced Frame

B.3.2.5 LC-Lateral Cross Member

Lateral cross members cannot be less than 203.5 mm (8 in.) long. LCs cannot have a bend; however, they can be a part of a larger, bent tube system, provided the minimum length is met between bend tangents. The cross members which connect the left and right points A, B, C, D, F, and E/G for 'Nose' cars (in which case DLC may be omitted) must be made of primary materials and shall meet the minimum required lengths. LCs are denoted by the points they connect (e.g., ALC, FLC, etc.). The LC at Point R (RLC) for Rear FAB systems may be secondary material and must meet the minimum length described above.

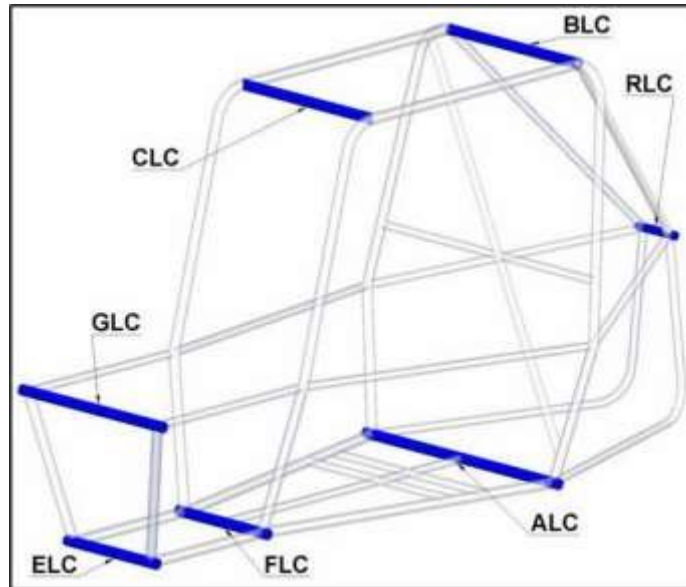

Figure B- 10: Roll Cage, LC

 **ALC member minimum length requirement should be 457mm (18in) and does not fall under the above clause of (8in) requirement.**

B.3.2.6 RRH (Rear Roll Hoop)

The RRH is a planar structure behind the driver's back and defines the boundary between the front-half (fore) and rear-half (aft) of the roll cage. The driver and seat must be entirely forward of this panel. The RRH is substantially vertical but may incline by up to 20 deg. from vertical. The minimum width of the RRH, measured at a point 686 mm (27 in.) above the inside seat bottom, is 736 mm (29 in.). In addition to this, the minimum width of the RRH measured 14 above the inside seat bottom should be a minimum of 32 inches. The vertical members of the RRH may be straight or bent and are defined as beginning and ending where they intersect the top and bottom horizontal planes (points AR and AL, and BR and BL in Figure B-11). The vertical members must be continuous tubes (i.e., not multiple segments joined by welding). The vertical members must be joined by ALC and BLC members at the bottom and top. ALC and BLC members must be continuous tubes or adhere to B.3.2.14 - Butt Joints. ALC, BLC, RRH members, LDB, and the shoulder belt tube must all be coplanar.

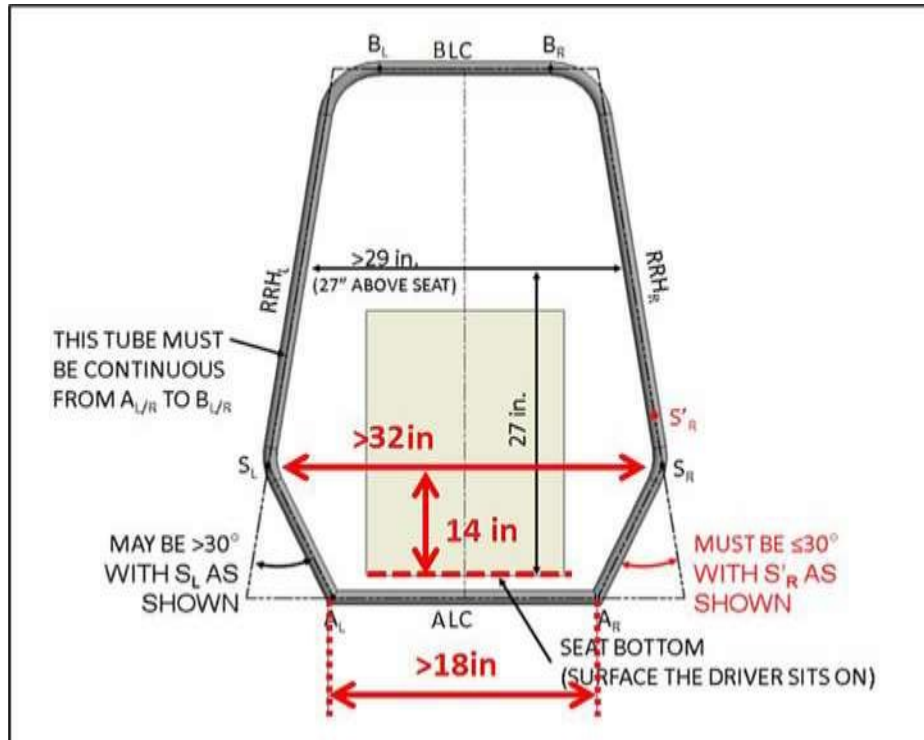

Figure B- 11: Roll Cage, RRH

B.3.2.7 LDB Lateral Diagonal Bracing

The RRH must be diagonally braced. The diagonal brace(s) must extend from one RRH vertical member to the other. The top and bottom intersections of the LDB members and the RRH vertical members must be no more than 127 mm (5 in.) from points A and B. The angle between the LDB members and the RRH vertical members must be greater than or equal to 20 deg. Lateral bracing may consist of more than one member.

A single straight LDB is exempt from the maximum length in B.3.2.1 - Member Requirements.

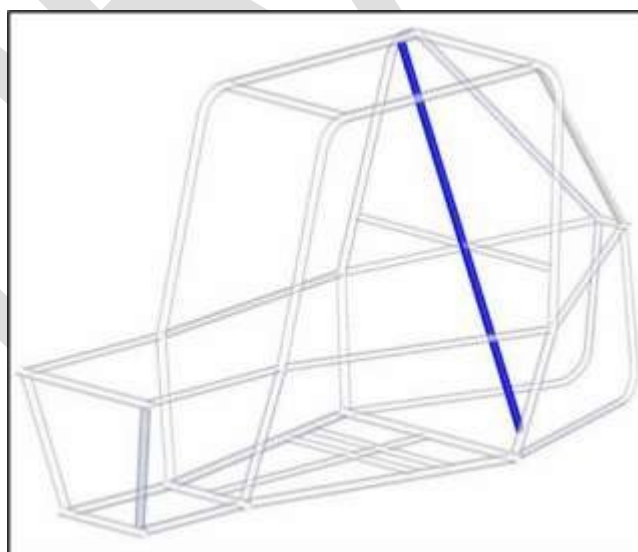

Figure B- 12: Roll Cage, LDB

☑ If more than one member is used for LDB (as shown in Figure B-13), both members must meet at the same point.

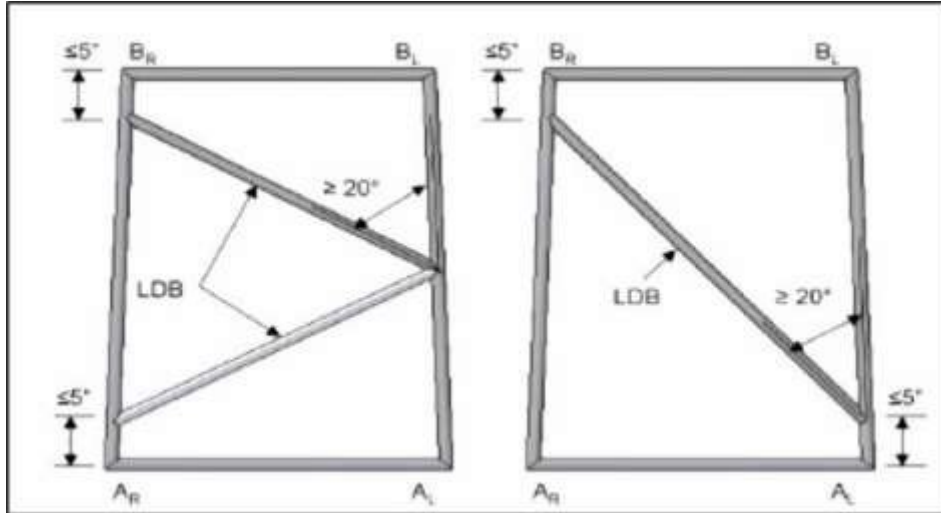

Figure B- 13: Roll cage, LDB

B.3.2.8 RHO Roll Hoop Overhead Members

The aft (rearward) ends of the RHO members intersect the RRH within 51 mm (2.0 in.) of Points BR and BL (defined by BLC). The forward ends of the RHO members (intersection with the CLC) define points CR and CL (Figure B-14). CLC, BLC, and RHO members must all be coplanar, and bends at the aft (rearward) ends of the RHO members are not permitted.

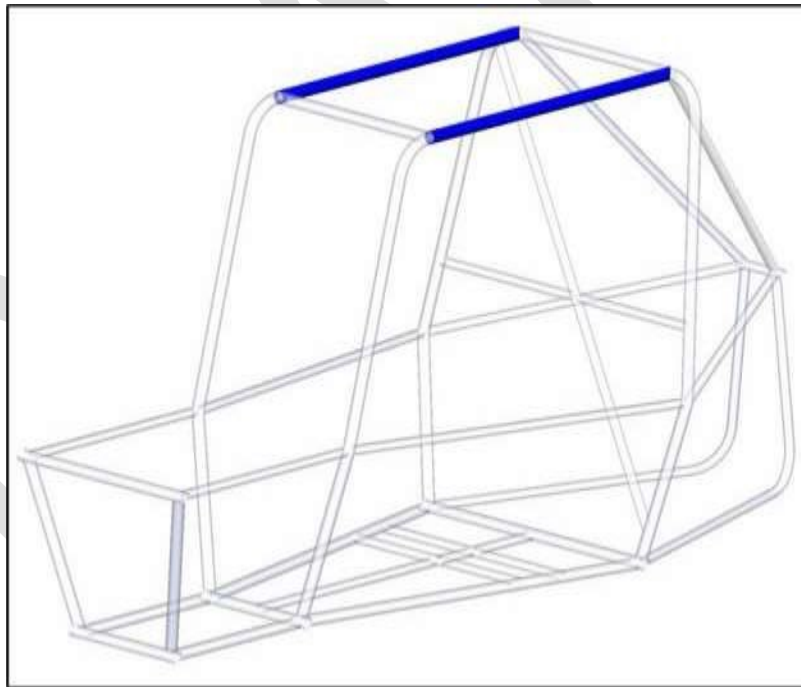

Figure B- 14: Roll Cage, RHO

When a bend is used at Point CR/CL or BR/BL these points are defined at the start of the bend on the top-most plane of the Roll Cage. The ends of the BLC define the location of points BL and BR. For cars constructed with bends at the top of the RRH, point B shall be on the inside end of the bend. Point B may not reside on the bend or a linear distance from the end of the bend.

Points CR and CL must be between at least 305 mm (12 in.) forward of a point, in the vehicle's side view, defined by the intersection of the RHO members and a vertical line rising from the aft end of the seat bottom.

This point on the seat is defined by the seat bottom intersection with a 101 mm (4 in.) radius circle which touches the seat bottom and the seat back. The top edge of the template is exactly horizontal to gravity.

Points CR and CL and Points BR and BL must also be no lower than the top edge of the template, 1041.4 mm (41 in) above the seat, and shall satisfy the Lateral Space requirements in Rule B.3.3.1 - Lateral Space.

The top, longitudinal edge of the template shall be oriented exactly horizontally to gravity.

The two RHO members must be braced using a diagonal member confirming Rule 3.2.1 Secondary member as highlighted in blue in Figure B - 15. The end points of the diagonal members welded must lie in the same plane as the RHO members and must be less than 3 inches away from points CR/CL and BR/BL respectively measured in the direction of the vehicle's longitudinal axis.

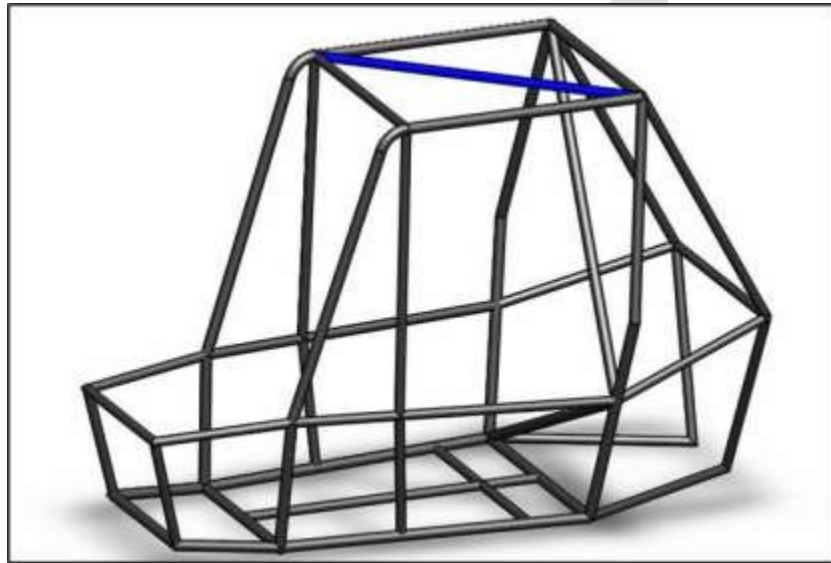

Figure B- 15: Diagonal Bracing for RHO members

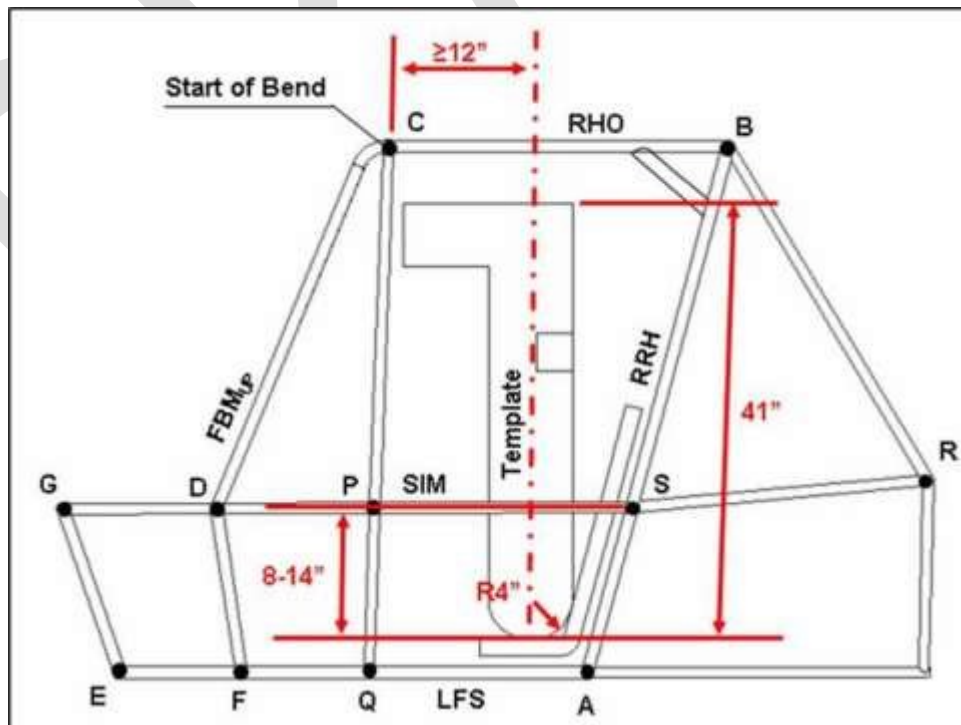

Figure B- 16: Roll Cage, Template Installation

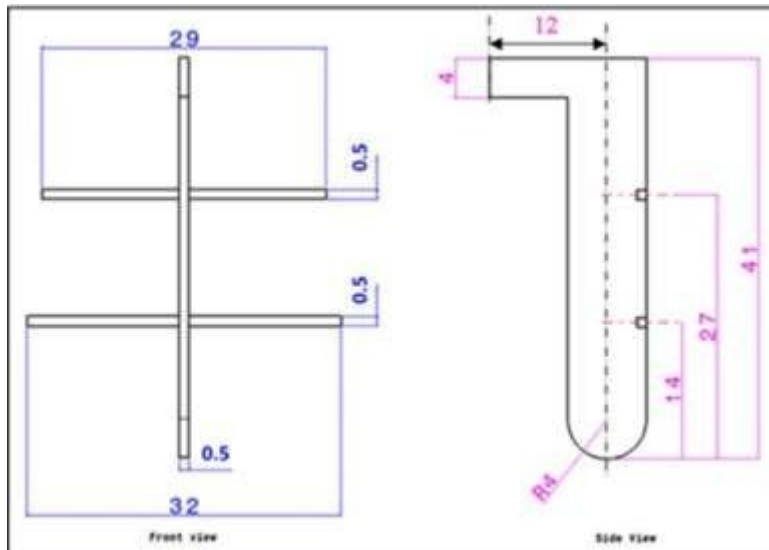

Figure B- 17: Roll Cage Template Drawing (All Dimensions are in inches)

B.3.2.8.1 Gussets for Lateral Clearance

If a gusset is used to brace the RHO and RRH to achieve the Lateral Clearance in Rule B.3.3.1 - Lateral Space the added members must be a primary material (B.3.2.16 - Roll Cage Materials); completely welded around the circumference of both ends of the gusset.

Gusset members connecting the SIM to RRH or FBM to achieve the Lateral Clearance in Rule B.3.3.1 - Lateral Space may be primary or secondary material (B.3.2.3 - Secondary Members) and must be closed in with Body Panels per Rule B.8.5 - Body Panels

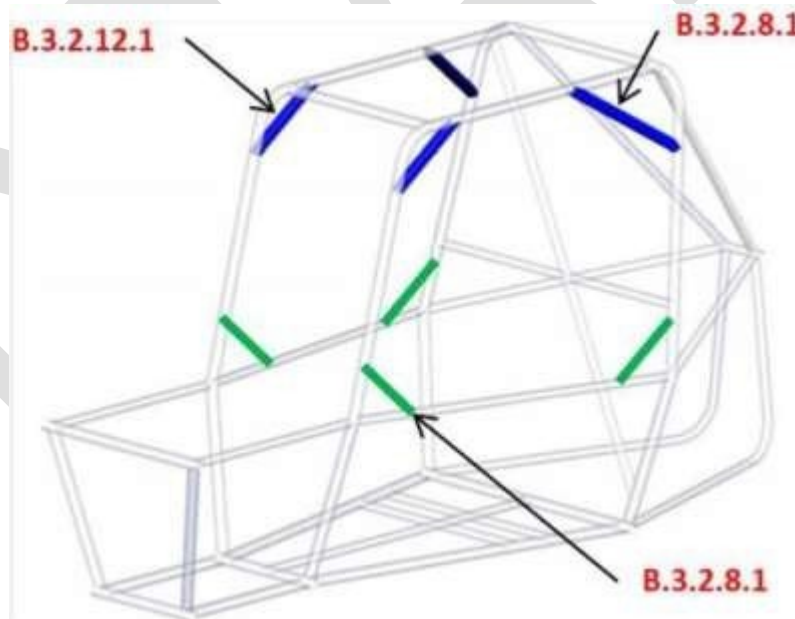

Figure B- 18: Roll Cage, Gussets

B.3.2.9 LFS – Lower Frame Side Members

The two Lower Frame Side members define the lower right and left edges of the roll cage. These members are joined to the bottom of the RRH at Point A and extend generally forward, at least as far as a point forward of every driver’s heel, when seated in a normal driving position. The forward ends of the LFS members are joined by a lateral cross member, FLC (Figure B-10). The intersection of the LFS members and the FLC defines the points FR and FL. In ‘Nose’ designs, as shown in Figure B-19, the LFS extends forward to Point E and is joined by a lateral cross member FLC and ELC (Figure B-10).

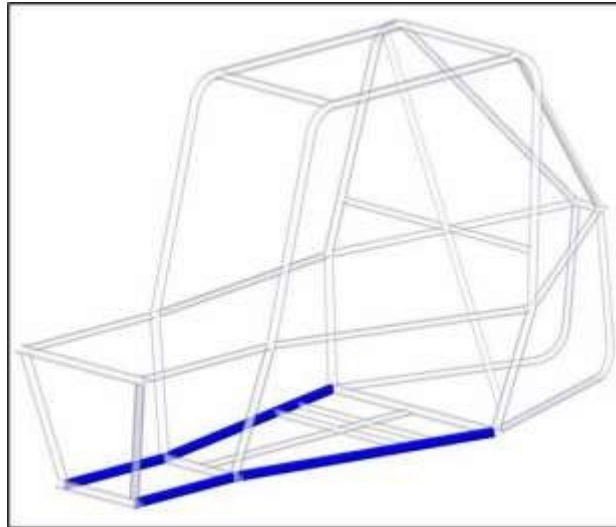

Figure B- 19: Roll Cage, LFS

B.3.2.10 SIM – Side Impact Members

The two Side Impact Members (SIM) define a horizontal mid-plane within the roll cage. These members are joined to the RRH, defining Point S, and extend generally forward, at least as far as a point forward of every driver’s toe, when seated in a normal driving position. The forward ends of the SIM members are joined by a lateral cross member, DLC. The intersection of the SIM and DLC defines the points DR and DL. The SIM members must be between 203 mm (8 in.) and 356 mm (14 in.) above the inside seat bottom (Figure B-16) at all positions between points S and D. In ‘Nose’ designs, as shown in Figure B-20, the SIM extends forward to Point G, and is joined by a lateral cross member GLC (Figure B-10). In this case, DLC may be omitted if GLC provides adequate protection for the driver’s toes as noted below.

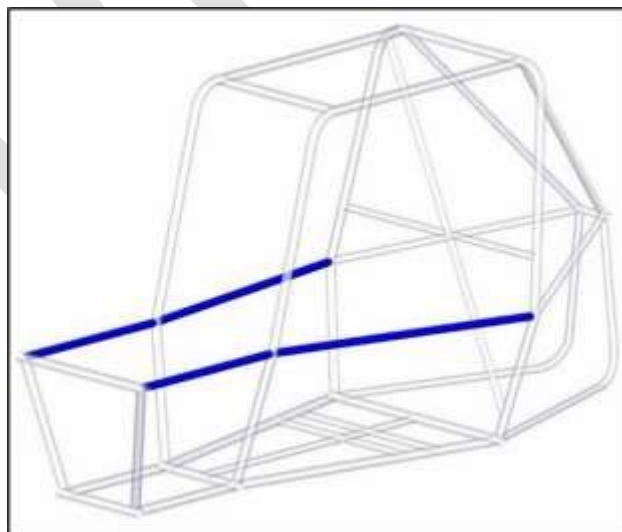

Figure B- 20: Roll Cage, SIM

Every driver’s foot must be entirely behind the plane defined by points FR, L, and DR, L. If DLC is below the driver’s toes, then an additional primary material Lateral Cross Member must run between the FBM members above the driver’s toes.

In ‘Nose’ designs, every driver’s foot must be entirely behind the plane defined by points GR, L, and ER, L. If GLC is below the driver’s toes, then an additional primary material Lateral Cross Member must be run between FBM or SIM members above the driver’s toes.

B.3.2.11 USM – Under Seat Member

The USM must be positioned in such a way to prevent the driver from passing through the plane of the LFS in the event of seat failure. The USM may also serve as the mounting location for the seat and/or the anti-submarine belts per Rules B.4.5.3 - Seat Mounting Points and B.4.2.6.3 - Anti Submarine Belt Attachment.

Two options are given for the USM member:

- 1) Lateral USM - The two LFS members shall be joined by the Under Seat Members. The USM shall pass below the driver within the fore-aft envelope of the part of the template as noted in Figure B-17 that intersects the seat bottom.
- 2) Longitudinal USM - The ALC and FLC members shall be joined longitudinally by the Under Seat Member. The forward end of the USM may also terminate at an additional cross member made from a primary material that joins the LFS members between Point A and Point F. The USM must pass within the fore-aft envelope of the template as noted in Figure B-17 intersects the seat bottom and the lateral centerline of the seat.

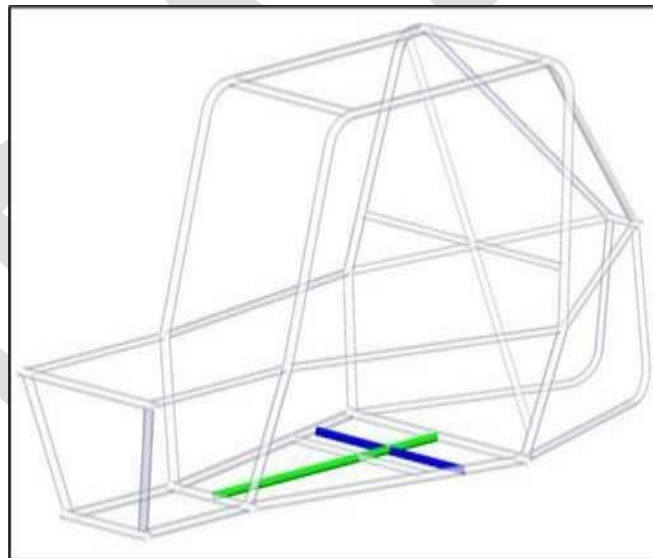

Figure B- 21: Roll Cage, USM

B.3.2.12 FBM – Front Bracing Members

Front Bracing Members must join the RHO, the SIM, and the LFS (Figure B-22) at Points C, D, and F. The upper front Bracing Members (FBMUP) must join points C on the RHO to point D on the SIM. The lower front Bracing Members (FBMLOW) must join point D to point F. The FBM must be continuous tubes. The angle between the FBMUP and the vertical must be less than or equal to 45 deg. If Front FAB, per Rule B.3.2.13.1 - Front Bracing, is used there is no angle requirement between FBM and vertical.

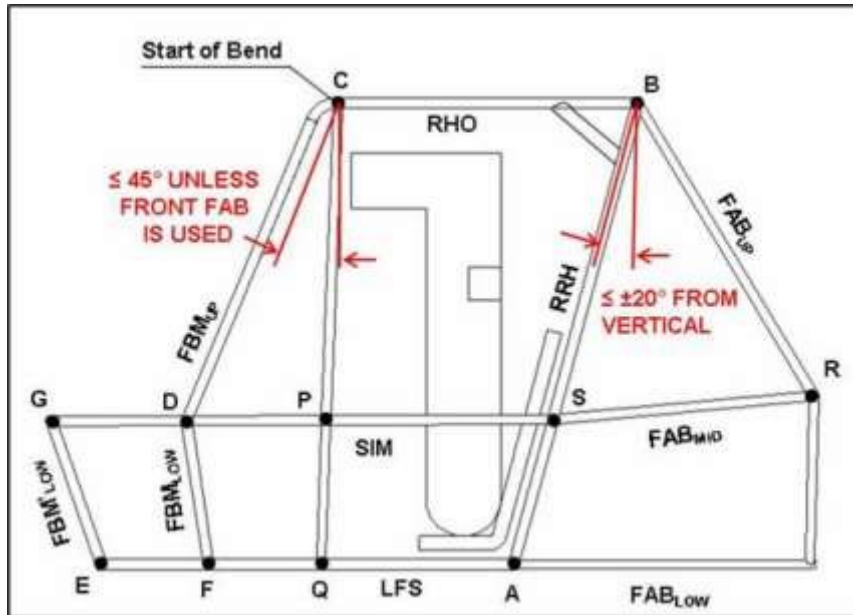

Figure B- 22: Roll Cage, FBM

B.3.2.12.1 Gussets for RHO and FBM

If the RHO and FBM on one side of the vehicle are not comprised jointly of one tube, bent at point C, then a gusset is required at point C to support the joint between the RHO and the FBM. The total weld length of the gusset must be two times the tubing circumference (of the primary material). Thus, if a tube is used to brace the FBM and RHO, it must be the primary material. Plate gussets may be used if the thickness of the material meets or exceeds that of the primary material used. Figure B-18: RHO / FBM Gussets

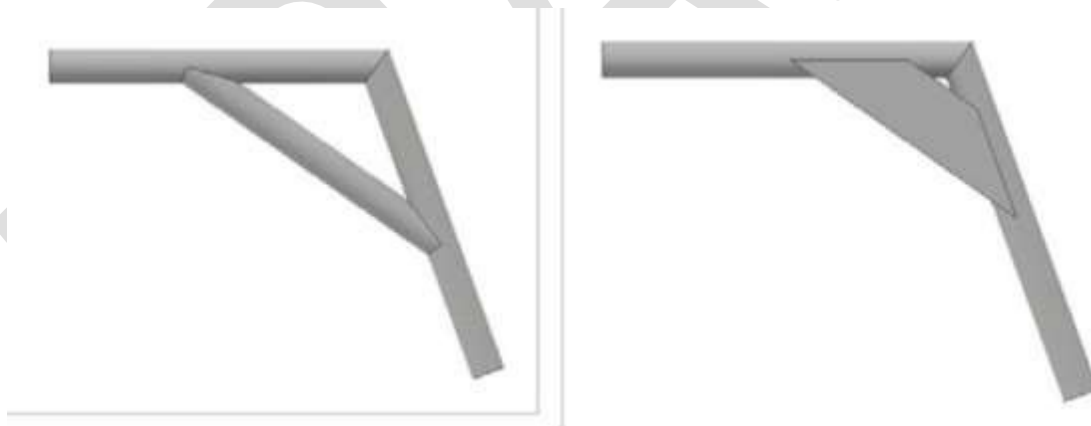

Figure B- 23: RHO / FBM Gussets

B.3.2.13 FAB – Fore - Aft Bracing

The RRH must be restrained from rotation and bending in the side view by a system of triangulated bracing. Bracing must either be front bracing or rear bracing:

- Rear Bracing - directly restrain both points B from longitudinal displacement in the event of failure of the joints at points C; or
- Front Bracing - restrain both points C from longitudinal and vertical displacement, thus supporting points B through the RHO members. A better design will result if both front and rear bracing are incorporated.

Members used in the FAB systems must not exceed 1016 mm (40 in.) in unsupported length. Triangulation angles (projected to the side view) must be at least 20 deg. between members.

B.3.2.13.1 Front Bracing

Front systems of FAB must connect the FBMUP members to the SIM members (on the same sides). The intersection with the FBMUP members must be within 127 mm (5 in.) measured as a straight-line distance from centerline to centerline of point C. The intersection with the SIM members defines Point P must be vertically supported by further members connecting the SIM members to the LFS members which define point Q. Points P and Q exist only with complete Front Bracing.

B.3.2.13.2 Rear Bracing

Rear systems of FAB must create a structural triangle, in the side view, on each side of the vehicle. Each triangle must be aft of the RRH, include the RRH vertical side as a member, and have one vertex at Point B and one vertex at either Point S or Point A. The tubes forming this structural triangle must be continuous members, but bends of less than 30 deg. are allowable. The third (aft) vertex of each rear bracing triangle, Point R (Figure B-24), must additionally be structurally connected to whichever Point, S or A, is not part of the structural triangle. This additional connection is considered part of the FAB system and is subject to B.3.2.1 - Member Requirements, but may be formed using multiple joined members, and this assembly of tubes, from endpoint to endpoint, may encompass a bend of greater than 30 deg.

Attachment of rear system FAB must be within 127 mm (5 in.) of Point B and must be within 51 mm (2 in.) of points S and A, on each side of the vehicle. Distances are measured as a straight-line distance from centerline to centerline. The aft vertices, at Point R, of the FAB structural triangles, must be joined by an LC.

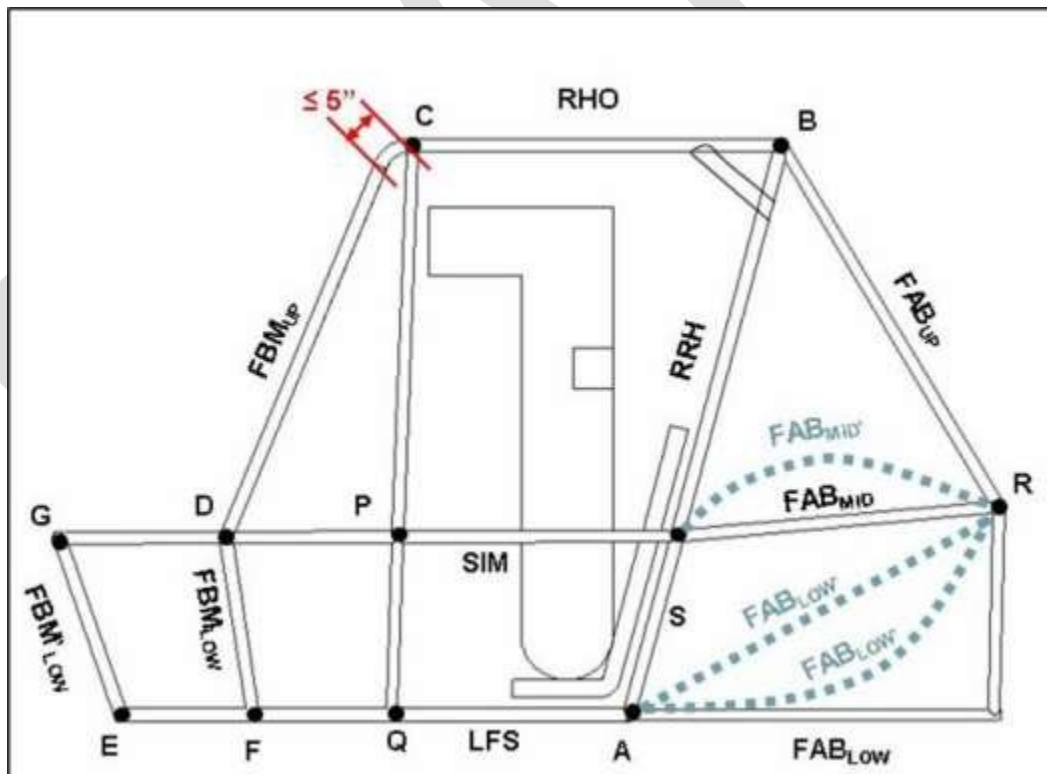

Figure B- 24: Roll Cage, FAB

B.3.2.14 Butt Joints

B.3.2.14.1 Requirement

Roll cage members which are made of multiple tubes, joined by welding, must be reinforced with a welding sleeve. Many roll cage members are required to be continuous tubes and may not be made of multiple pieces. Tubes that are joined at an angle greater than 5 deg. need not be sleeved; angles of less than 5 deg. will be considered butt joints.

B.3.2.14.2 Size

Sleeves must be designed to fit tightly on the inside of the joint being reinforced. External sleeves are not allowed. Sleeves must extend into each side of the sleeved joint, a length of at least two times the diameter of the tubes being reinforced, and be made from steel at least as thick as the tubes being reinforced.

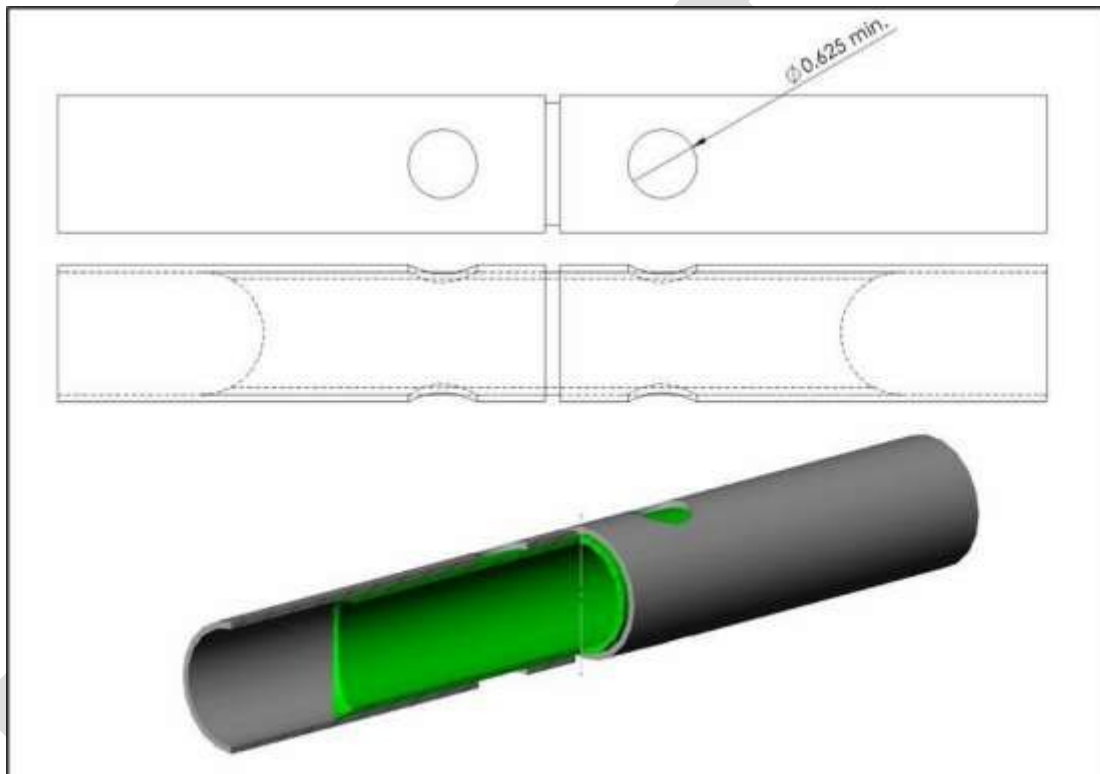

Figure B- 25: Roll Cage, Butt Joint Tube Sleeve

B.3.2.14.3 Welding

The general arrangement of an acceptable sleeved joint is shown in Figure B-25. A butt weld and four (4) rosette welds are required. Two (2) rosette welds are required for each tube piece. Rosette welds are to be made in holes of a minimum diameter of 16 mm (0.625 in.).

A minimum of 102 mm (4.0 in.) of a linear weld is required to secure the sleeve inside the joint, including the butt joint and the rosette welds.

B.3.2.15 Welding Process Check

Each person who makes any welded joint on any of the vehicle's roll cage elements must personally make two welding samples (defined below), using the same materials and processes as used in the roll cage element welds. All welding samples must be submitted at Technical Inspection. Vehicles for which complete sets of welding samples are not submitted, or for which any of the welding samples are judged inadequate, will not be allowed to compete in dynamic or endurance events.

Welding samples must be made from the same tube material, diameter, and thickness as the welds made by each person on the roll cage elements. For information on best practices for weld samples, see Tech Team Documentation Additional Guidelines and Resources Section.

All weld samples shall be labeled by permanent means such as engraving, etching, or stamping with all of the following information:

- College Name or College Initials
- Welder Name or Welder Initials
- Date of construction of weld sample

Sample 1 – Destructive Testing:

In a 90-degree joint, the leg length is unrestricted (Figure B-26). This joint must be destructively tested causing the joint to fail in the base material (as opposed to the weld metal). The testing method is free -either tensile or bending failure may be induced; however, the peak stress must be located at the weld. In the case of bending failure, take care that the largest bending moment is located at the weld.

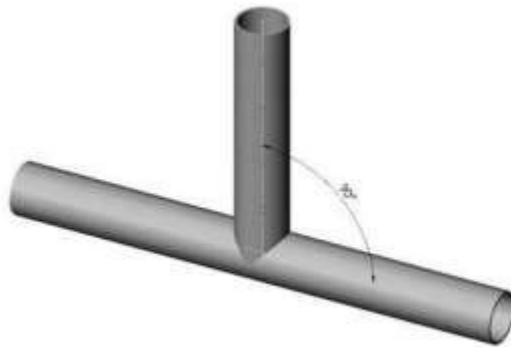

Figure B- 26: Roll Cage, Welding Sample 1

Sample 2 – Destructive Inspection

Two tubes are joined at a 30-degree angle with a length of at least 150 mm (5.9 in.) from the center of the joint (Figure B-27). The sample must be sectioned along the length of the tube to reveal adequate and uniform weld penetration (Figure B-27).



Figure B- 27: Roll Cage, Welding Sample 2

B.3.2.16 Roll Cage Materials

The material used for the Primary Roll Cage Members and bracing must meet one of the following requirements:

- Circular steel tubing with an outside diameter of 25 mm (1.0 in) and a wall thickness of 3 mm (0.120 in.) and carbon content of at least 0.18%.
- A steel shape with bending stiffness and bending strength exceeding that of circular steel tubing with an outside diameter of 25 mm (1.0 in.) and a wall thickness of 3 mm (0.120 in.). The wall thickness must be at least 1.57 mm (0.062 in.) and the carbon content must be at least 0.18%, regardless of material or section size. The bending stiffness and bending strength must be calculated about a neutral axis that gives the minimum values.

Docol R8 tubing is permitted.

 **Docol R8 tubes are not intended to undergo any heat treatment after welding and sizing as any heat treatment may alter the mechanical properties of the material.**

- Bending stiffness, k_b , is given by:

Where:

$$k_b = EI$$

E - Modulus of elasticity (205 GPa for all steels)

I - Second moment of area for the structural cross-section

- Bending strength, S_b , is given by:

$$S_b = \frac{S_y I}{c}$$

Where:

S_y - Yield strength (365 MPa for 1018 steel)

c - Distance from the neutral axis to extreme fiber

Documentation of the equivalency must include:

- Typed calculations to be presented at Technical Inspection which proves sufficient bending stiffness and bending strength. All calculations must be in SI units, to three significant figures to the nominal tube sizes as specified by the invoice. Teams shall show figures for 1018 steel and the substitute material.
- Invoices of the roll cage materials.
- Material tests or certifications, specify the carbon content and yield strength.

 **Teams are not allowed to use old test reports.**

B.3.3 Driver Clearance

B.3.3.1 Lateral Space

Minimum space is based on clearances between the driver and a straight edge applied to any two points on the outside edge of the roll cage structure. The driver's helmet shall have 152 mm (6 in.) clearance, while the driver's shoulders, torso, hips, thighs, knees, calves, arms, elbows, and hands shall have 76 mm (3 in.) clearance. Clearances are relative to any drivers selected at technical inspection, seated in a normal driving position, and wearing all required equipment.

For any member to be a part of the roll cage, that member must be listed in B.3.2.2 - Primary Members, otherwise it is assumed to have no contribution (Suspension components, additional gussets, and cross members are examples of members which do not conform to B.3.2.2). If any triangulating members are joining the RHO to the vertical members of the Rear Roll Hoop, and these triangulating members conform to B.3.2.16 - Roll Cage Materials, then the virtual side surfaces may be extended by an outboard crease over the triangulating members.



Figure B- 28

B.3.3.2 Vertical Space

The driver's helmet shall have 152 mm (6 in.) minimum clearance from any two points among those members that make up the top of the roll cage. These members are the RHO members (exclusive of any covering or padding); the RRRH upper, LC; and the LC between points C (left and right). In an elevation (side) view, no part of the driver's body, shoes, and clothing may extend beyond the envelope of the roll cage.

B.3.4 Sharp Edges

The entire vehicle, including the roll cage, shall have no exposed sharp edges which might endanger the driver, track workers, or people working around the vehicle while the vehicle is in any attitude (static, dynamic, inverted, etc.).

B.3.5 Bolted Roll Cages

Bolted Roll cages joints are acceptable only if the following requirements are met (Figure B-29):

- 1) Flanges or tabs must be twice (2x) the thickness of the frame tube and made of the same material. They must be properly welded to each tubing part to be joined. The face of the flange must be perpendicular to the axis of the frame tube.
- 2) The radius of the flange must be at least 25 mm (1.0 in.) larger than the outer radius of the frame tube.

- 3) The gap between the faces of the flanges (before being tightened) must be no greater than 0.07 mm (0.003 in).
- 4) The flanges must be attached with at least 3 bolts with a minimum diameter of 8 mm (0.313 in.), equally spaced on the flanges. The minimum edge distance between the bolt holes and the edge of the flanges must be twice the bolt diameter.
- 5) Pin Joints are not permitted

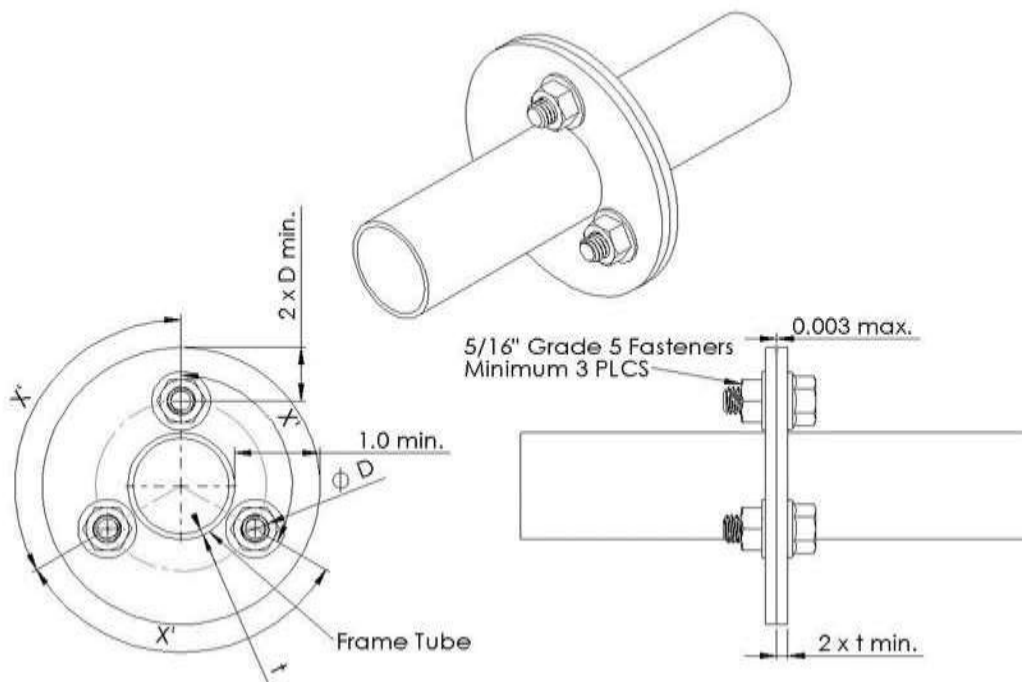

Figure B- 29: Roll Cage, Required Joint for Removable Members

B.3.6 Drilled Frame Members

B.3.6.1 Sleeved Joints

Frame members which need to be drilled for mounting fasteners or routing accessories must be reinforced with a weld-in sleeve. Sleeves must be designed to fit tightly on the inside of the hole or joint being reinforced. Sleeves must extend beyond the tube on both sides and be fully welded to the tube. An unacceptable joint is denoted by a red “X”. An acceptable joint is denoted by a green “O” in Figure B-30.



Figure B- 30: Roll Cage, Required tube sleeve for drilled holes

B.3.6.2 Drilled Holes

Single drilled holes in members with a diameter less than or equal to 5 mm (0.197 in) do not require a sleeve.

ARTICLE B.4: DRIVER RESTRAINT

B.4.1 Function

The driver restraint system shall function to safely and securely hold the driver within the envelope of the vehicle's roll cage. The driver restraint system shall also quickly and completely disengage when required to allow the driver a minimum egress time. The driver restraint system consists of a safety harness, arm restraints, and the vehicle's seat. The driver restraint system shall be fully functional and properly worn whenever the driver is seated in the vehicle.

B.4.2 Driver Harness

The driver harness shall consist of a 5-point (or more) system comprised of two shoulder belts (left and right), two lap belts (left and right), and one or more anti-submarine belts all joining at a single, central buckle (disconnect point). The anti-submarine belt serves to positively locate the buckle and prevent the driver from riding under the lap belts.

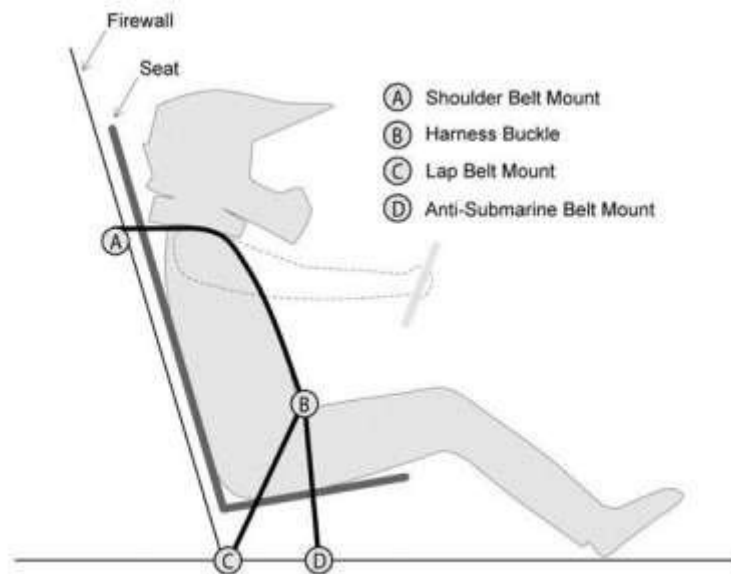

Figure B- 31: Driver Harness Schematic

B.4.2.1 Certification

All driver restraint systems shall meet either SFI Specification 16.5/16.1 or FIA specification 8853/98. The material of shoulder and lap belts shall be of Nylon or Dacron polyester and in new or like-new condition, 76 mm (3.0 in.) in width, and free from injurious defects. Anti-submarine belts shall meet the same conditions but have a minimum width of 51 mm (2.0 in.).

 **Some 2.0-inch anti-submarine belts measure 1.75 in. actual minimum widths and are acceptable for use.**

Refer to the link below for a list of approved manufacturers for SFI Rated driver restraint assemblies:

[SFI 16.1 Manufacturers List \(sfi.org\)](https://www.sfi.org/16.1-Manufacturers-List)

B.4.2.2 Expiration

In December of 2016, SFI updated the design and format of driver harness expiration tags. Manufacturers are permitted to use old tags until their supply runs out. BAJA SAEINDIA® permits the use of driver harnesses with the old and the new tag design, provided:

For old style tags: On April 1st of the competition year, harnesses shall be no more than three (3) years old.

For new style tags: Harnesses with expiration tags bearing a “Valid Until” date that is on or after the last day of the current competition.



Figure B- 32: Driver Harness, SFI Tag, Old Style (Left), New Style (Right)

B.4.2.3 Release Mechanism

All belts in the driver harness must join to a single, central, metal-to-metal, lever-type, quick-release buckle. Cam-Lock and other enclosed buckles susceptible to jamming from small debris (such as sand particles) are explicitly prohibited. The release mechanism (buckle) shall be protected against accidental unfastening from a direct pull, rollover, or slide along the side.

B.4.2.4 Shoulder Belts

The shoulder harness shall be of the over-the-shoulder type. Only separate shoulder straps are permitted. “Y”-type shoulder straps are explicitly prohibited.

B.4.2.4.1 Positioning, Vertical

The shoulder belt mounting point (A) (see Figure B-33) shall be positioned no higher than vertical level with each driver’s shoulders, and no lower than 102 mm (4.0 in.) vertically below each driver’s shoulders.

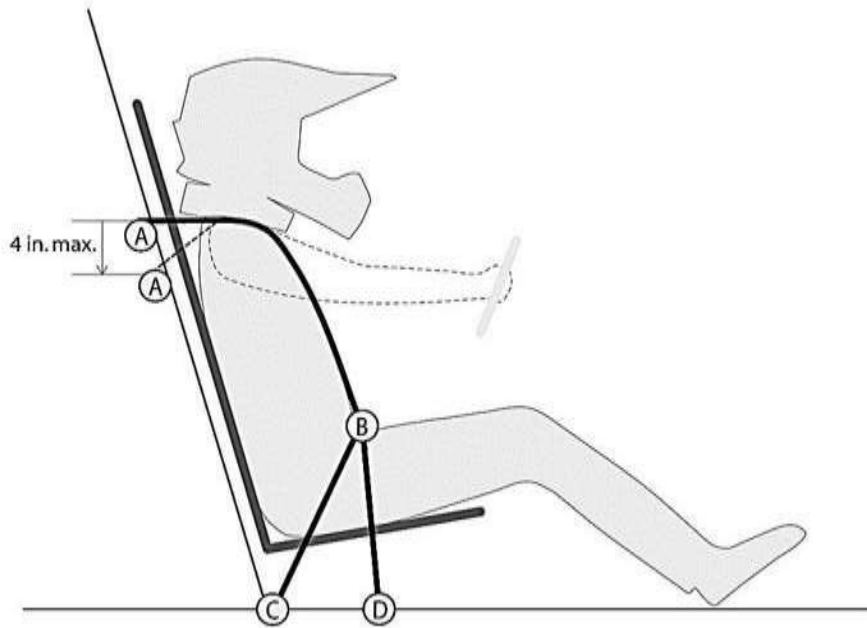

Figure B- 33: Driver Harness, Shoulder Harness Vertical Position

B.4.2.4.2 Positioning, Lateral

The lateral spacing of the shoulder belts shall be between 152 mm (6.0 in.) and 229 mm (9.0 in.) when measured center-to-center. See Figure B-34. The lateral position of the shoulder belts along their mounting tube must be restrained by a structure other than the firewall.

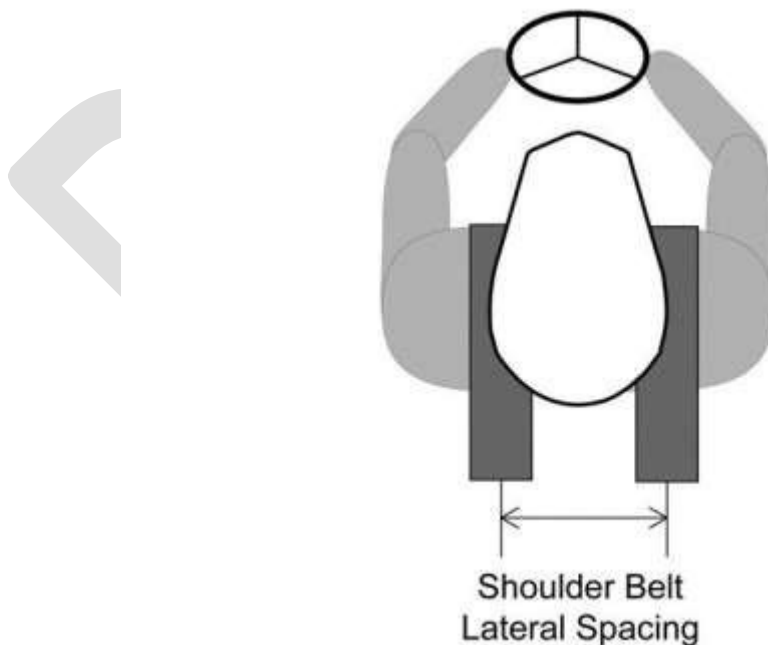

Figure B- 34: Driver Harness, Shoulder Harness Lateral Position

The shoulder belts shall be looped and secured around a straight, horizontal tube welded within the plane of the RRH. The tube that the shoulder belts are looped around shall meet the requirements of a secondary member, B.3.2.3 - Secondary Members. Provisions for lateral position restraint shall be provided. Firewall material is not acceptable for lateral position restraint. See Figure B-35 for details.



Figure B- 35: Driver Harness, Shoulder Harness Lateral Restraint

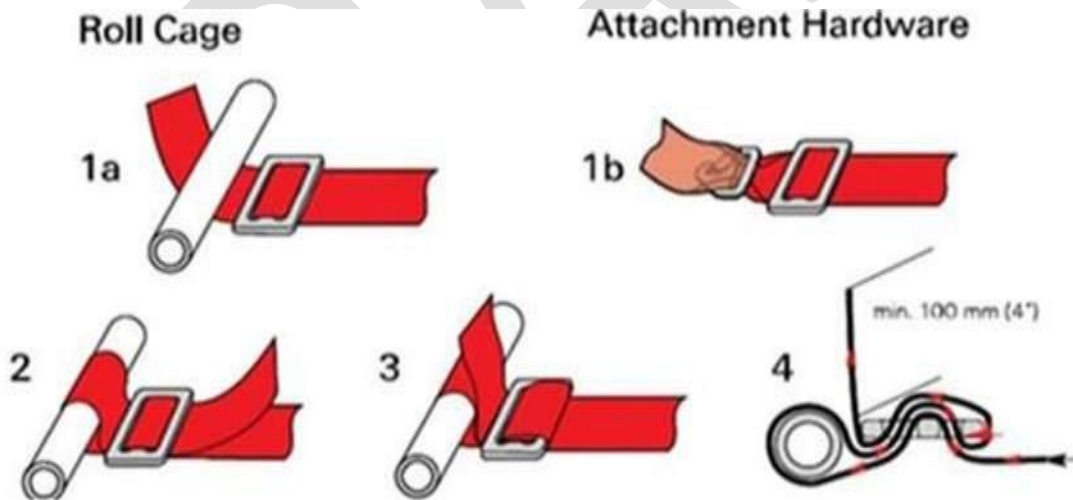

Figure B- 36: Driver Harness, Diagram of Proper Wrapping of Webbing

B.4.2.4.4 Redirection

The shoulder belts must run directly from their mountings to the driver's shoulders, without redirection by any part of the vehicle or its equipment, including seats.

The webbing shall not be twisted or rotated at any point along the path of the shoulder belt.

B.4.2.4.5 Adjustment

The shoulder belts shall be in proper adjustment for the driver at all times. When the driver harness is worn, each buckle or adjuster in the system shall have excess adjustment capacity to fit all drivers. The minimum length of excess shoulder harness webbing is 102 mm (4.0 in). See Figure B-36

B.4.2.4.6 Protection

The shoulder belts shall be protected from potential damage from aft of the RRH. The firewall must protect the shoulder belts. The firewall may be pocketed or extended to facilitate this requirement, as long as no open gaps result. Excess shoulder belt webbing shall be neatly contained and kept within the roll envelope of the vehicle. Proper grommets should be provided to cover the cut in the firewall completely. Visible gaps to be avoided.

B.4.2.5 Lap Belts

The lap belt halves must run directly from the buckle, over the driver's hips, and to their mounting points without redirection by any part of the vehicle or its equipment (including the seat). The lap belt halves must be mounted to frame tabs using the bracket supplied with the safety harness. Lap belts may not be mounted by wrapping around tubes.

B.4.2.5.1 Positioning

The lap belt (point B to point C) in Figure B-37 shall be positioned such that it passes over the driver's pelvic area below the Anterior Superior Iliac spine (the hip bones). The lap belt shall not be worn over the driver's intestines or abdomen.

In a side view, the lap belt must be at a minor angle (angle "L" or angle BCD) of between 45 degrees and 80 degrees to the horizontal. This requirement means that the centerline of the lap belt at the seat bottom will be approximately 76 mm (3.0 in.) forward of the bottom of the seat back.

 **Quick disconnect fasteners for body panels are recommended and facilitate a faster technical inspection process.**

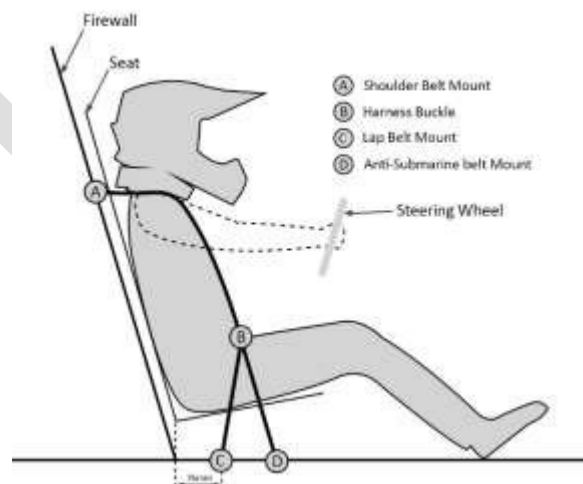

Figure B- 37: Driver Harness, Lap Belt Angle

The lap belts shall be securely attached to the vehicle frame with metal tabs joined by a threaded fastener. Lap belts wrapped around tubes or secured with eyebolts are explicitly prohibited. The webbing shall be wrapped per Figure B-36: Driver Harness, Diagram of Proper Wrapping of Webbing.

Threaded fasteners in the driver restraint system shall meet the requirements of Article 12 - Fasteners.

Threaded fasteners in the driver restraint system shall match the nominal diameter of the mounting holes in the lap belt mounting bracket. For example, if a lap belt mounting tab is drilled for a 13 mm (0.5 in.) hole, the fastener, and the frame lap belt tab shall be 13 mm (0.5 in.) in diameter.

- The frame tabs which accept the metal lap belt tabs shall meet the following requirements:
- The frame lap belt tabs shall be no less than 2.3 mm (0.090 in.) thick and configured for double shear mounting. Frame lap belt tabs configured in bending are explicitly prohibited. See Figure B-38.
- The frame lap belt tabs shall be attached to the frame with no less than 38 mm (1.5 in.) of weld length per tab.
- The frame lap belt tabs shall have no less than 6.4 mm (0.25 in.) of edge distance. (Edge distance is the measurement from the edge of the bolt hole to the outside edge of the tab.)
- The frame lap belt tabs and lap belt shall be installed such that the lap belt tabs pivot freely.
- The frame lap belt tabs and their mounting shall be stiff and not readily deformed.
- No lightning holes or other cut-outs are permitted on the frame lap belt tabs.

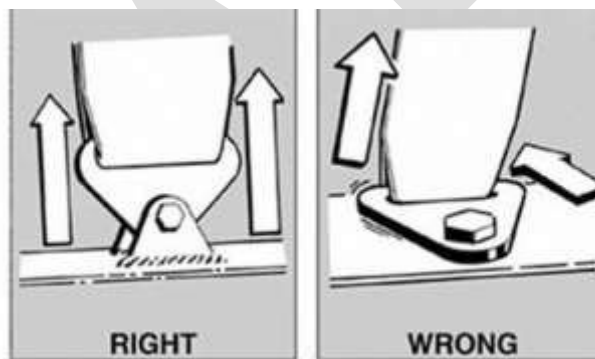

Figure B- 38: Driver Harness, Lap Belt Tab Orientation

B.4.2.5.3 Redirection

The lap belts shall be routed directly from the mounting points over the driver's hips and to the release mechanism (buckle) without redirection by any part of the vehicle or its equipment (including the seat).

The webbing shall not be twisted or rotated at any point along the path of the lap belt.

B.4.2.5.4 Adjustment

The lap belts shall be in proper adjustment for the driver at all times. When the driver harness is worn, each buckle or adjuster in the system shall have excess adjustment capacity.

B.4.2.5.5 Protection

The lap belts shall be protected from potential damage by the vehicle's body panels. Excess lap belt webbing shall be neatly contained and kept within the roll envelope of the vehicle.

B.4.2.6 Anti-Submarine Belts

B.4.2.6.1 Number of Points

The anti-submarine belt (Line BD in Figure B-39) shall be at least a single-point mount (a 5-point driver harness configuration). Driver harnesses of the 6-point and 7-point types are permitted. A 6-point system utilizes two anti-submarine belt mounting points. A 7-point system utilizes three anti-submarine belt mounting points.

B.4.2.6.2 Positioning

Anti-submarine belts shall be mounted to the vehicle frame at a point aft of the chest line as denoted by a positive angle "S" in Figure B-39. The anti-submarine belt mounting point shall be forward of the lap belt mounting points. The chest line passes through point B and is parallel to the driver's sternum. The antisubmarine belt angle (angle S) is suggested to be 20 deg. The anti-submarine belt shall be mounted either to a frame tab or wrapped around a frame member meeting at least the secondary member requirement.

6-point and 7-point harnesses shall be installed per the manufacturer's instructions. Teams shall be prepared to provide documentation of mounting instructions to TEJ at the time of technical inspection.

 **Quick disconnect fasteners for body panels are recommended and facilitate a faster technical inspection process.**

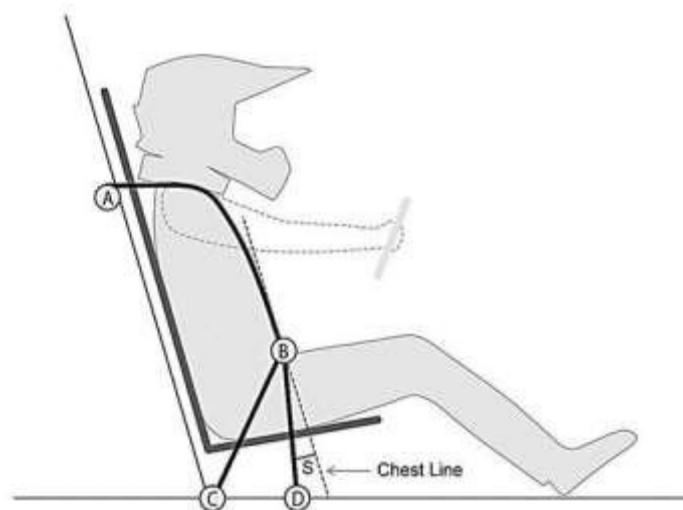

Figure B- 39: Driver Harness, Anti-Submarine Belt Angle

B.4.2.6.3 Attachment

The anti-submarine belts shall be securely attached to the vehicle frame by one of the following methods:

- Metal tabs are joined by a threaded fastener.
- Webbing wrapped around a frame member.
- Webbing wrapped around a bolt secured by metal tabs in double shear.

Anti-submarine belts secured with eyebolts are explicitly prohibited. The webbing shall be wrapped per Figure B-33: Driver Harness, Diagram of Proper Wrapping of Webbing.

Any threaded fastener in the driver restraint system shall meet the requirements of Part B: Article 12 – Fasteners

Threaded fasteners in the driver restraint system shall match the nominal diameter of the mounting holes in the lap belt mounting bracket. For example, if an anti-submarine belt mounting tab is drilled for a 13 mm (0.5 in.) hole, the fastener and the frame tabs tab shall be 13 mm (0.5 in.) in diameter.

The frame tabs which accept the metal anti-submarine belt tabs shall meet the following requirements:

- The frame anti-submarine belt tabs shall be no less than 2.3 mm (0.090 in.) thick and configured for double-shear mounting. Frame anti-submarine belt tabs configured in bending are explicitly prohibited.
- The frame anti-submarine belt tabs shall be attached to the frame with no less than 38 mm (1.5 in.) of weld length per tab.
- The frame anti-submarine belt tabs shall have no less than 6.4 mm (0.25 in.) of edge distance. (Edge distance is the measurement from the edge of the bolt hole to the outside edge of the tab).
- The frame anti-submarine belt tabs and lap belt shall be installed such that the lap belt tabs pivot freely.
- The frame anti-submarine belt tabs and their mounting shall be stiff and not readily deformed.
- No lightening holes or other cut-outs are permitted on the frame anti-submarine belt tabs

If the anti-submarine belt is wrapped around a frame member or a bolt, the following requirements shall be met:

- The anti-submarine belt mounting tube shall have features designed to limit total lateral movement to 25.4 mm (1.0 in.) or less.
- The anti-submarine belt webbing shall be protected from sharp edges such as bolt threads, tab edges, and
- The anti-submarine belt mounting tube or tube holding tabs shall meet the frame requirements of a secondary member. The mounting tube may be constructed of a single tube with bends or may be constructed with no more than three tubes and two mitered joints (excluding connections to the LFS). The anti-submarine belt mounting tube shall join both of the vehicle's LFS members and be oriented parallel to the LCs. The mounting tube may not be cantilevered off of another tube creating an undue bending moment.

B.4.2.6.4 Redirection

Redirection of the anti-submarine belt by a rigid frame, seat member, or seat edge is allowed. Redirected belt webbing must not contain a bend of more than 30 degrees (Figure B-40). The redirecting member or edge must be designed to prevent chaffing or abrasion of the belt webbing.

The webbing shall not be twisted at any point along the path of the anti-submarine belt.

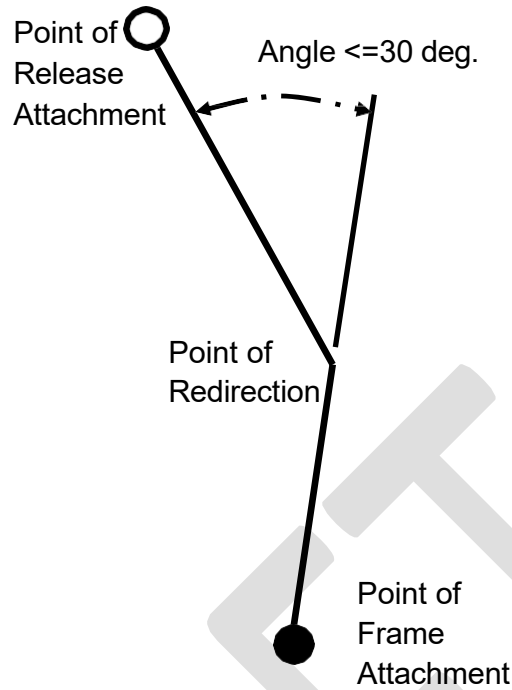

Figure B- 40: Driver Harness, Anti-Submarine Belt Redirection

B.4.2.6.5 Adjustment

The anti-submarine belts shall be in proper adjustment for the driver at all times. When the driver harness is worn, each buckle or adjuster in the system shall have excess adjustment capacity.

B.4.2.6.6 Protection

All anti-submarine belts shall be protected by the vehicle skid plate. Excess anti-submarine belt webbing shall be neatly contained and kept within the roll envelope of the vehicle.

B.4.3 Arm Restraints

In the event of a rollover, the driver's arms must be kept within the limits of the roll cage space (B.3.3.1 - Lateral Space) by use of arm restraints. Arm restraints must be securely fastened to the driver restraint system. Only commercially available arm restraints meeting SFI 3.3 are allowed. The arm restraints must independently connect to the safety belts. Refer to the link below for a list of approved manufacturers for SFI 3.3 rated driver's accessories:

[SFI 3.3 Manufacturers List \(sfifoundation.com\)](https://www.sfifoundation.com)

B.4.3.1 Certification

The restraints must be in overall good condition and show no signs of wear, no cuts chaffing or wear. The restraints must bear the appropriate labels.



Figure B- 41: Driver Harness, Arm Restraints

Manufacturers are required to ensure they have labeled the belts with a date of manufacture. The date tag may be separate from the SFI tag.

B.4.3.2 Expiration

In December of 2016, SFI updated the design and format of driver harness expiration tags. Manufacturers are permitted to use old tags until their supply runs out. BAJA SAEINDIA® permits the use of arm restraints with the old and the new tag design, provided:

For old style tags: On **April 1st** of the competition year, harnesses shall be no more than three (3) years old.

For new style tags: Harnesses with expiration tags bearing a “Valid Until” date that is on or after the last day of the current competition.

See Figure B-32 for more information.

B.4.3.3 Positioning

Arm restraints must be installed such that the driver can release the harness and exit the vehicle unassisted, regardless of the vehicle’s position. The arm restraint must be worn by the driver on the forearm just below the elbow. The driver must be able to reach the cockpit kill switch and steering wheel, but not allow their arms to exit the cockpit.

B.4.3.4 Attachment

Arm restraints shall be attached to the buckle of the driver harness when assembled.

B.4.4 Head Restraint

A head restraint must be provided to limit the rearward motion of the driver’s head from a normal driving position. The head restraint must be mechanically fastened to the vehicle, preferably to the vehicle frame. Hook-and-loop and adhesive methods are prohibited. Head restraints may also be mechanically fastened or integral to the driver’s seat.

Caution: HANS devices and Leatt braces are not allowed due to the improper fitment of these devices concerning nominal BAJA SAEINDIA® seat design and seating position.

B.4.5 Seats

The seat shall work in concert with the driver harness to secure the driver within the envelope of the roll cage. Seats shall be of conventional design. See details below. All seats shall be designed for the upright seating position. Suspension seats are prohibited. The upright seating position is defined by the angle of the driver’s back to a horizontal line. The seat back angle (Figure B-42) for an upright seating position is greater than 65 deg. As a reference, a completely upright driver will have a back angle of 90 deg.

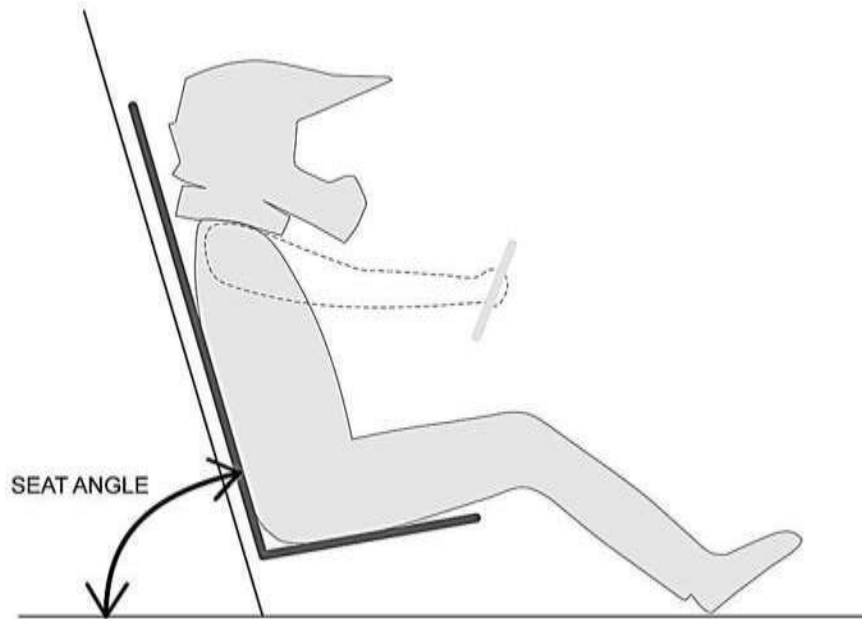

Figure B- 42: Seat Angle

B.4.5.1 Seat Construction

B.4.5.1.1 Conventional Seats

Conventional seats shall be generally rigid and be of metal or composite construction (fiberglass or carbon fiber). Seats constructed of thermoplastic are prohibited. The bottom and back panel of seats must have at least 2 inches of non-removable foam (in an uncompressed state, without the driver seated) on them. Conventional seats may also have a removable seat cover. Seats may be purchased from a manufacturer or constructed by teams.

B.4.5.1.2 Suspension Seats

Suspension seats, sling seats, hammock seats, or similar designs with webbing or cordage as the primary load path are explicitly prohibited.

B.4.5.2 Seat Design

Seats shall be designed to have at least two generally planar surfaces when the driver is seated in the vehicle. The seat back plane shall be inclined between 65 and 90 deg from horizontal as viewed from the side (see Figure B-42: Seat Angle). The seat bottom plane shall be underneath the driver and be horizontal or generally sloped such that the leading edge of the seat bottom plane is level with or higher than the intersection with the back plane. Seats may also include material oriented vertically along the sides of the seat bottom plane and the seat back plane designed to assist in laterally restraining the driver.

B.4.5.3 Seat Mounting Points (Conventional Seats)

B.4.5.3.1 Quantity

All seats shall have no less than six (6) total mounting points to the vehicle frame. Seats shall have no less than four (4) mounting points from the seat bottom plane and no less than two (2) mounting points from the seat back plane. The minimum fastener diameter for seat mounting points is 6.5 mm.

B.4.5.3.2 Arrangement

The seat bottom plane and seat back plane mounting points shall be generally symmetrical about the longitudinal center line of the seat itself or the vehicle. Seat back plane mounting points shall be at or near the plane of the RRH. All seat mounting points shall attach to the LFS, USM, RRH or other tubes having met the requirements of secondary frame members. Each seat bottom mount shall be designed to evenly distribute the vertical load.

B.4.5.3.3 Structure

Any tabs utilized in mounting the seat shall be a minimum thickness of 2.3 mm (0.090 in) and have at least 38 mm (1.5 in.) of weld length per tab.

Mounting Tabs shall not visibly deform when a load is applied. The average distance from the tab hole to the main tab weld line shall not exceed 25.4 mm (1.0 in.). Any tube used to mount the seat with radial holes drilled in the tube shall be sleeved and reinforced per rule B.3.6 - Drilled Frame Members.

ARTICLE B.5: DRIVER EQUIPMENT

- ☑ **The following items must have COLLEGE NAME INITIALS marked with PERMANENT MARKERS (in contrast with the safety gears) For example, for the college named, “XYZ Hub of Technology” mark as “X.H.T.” on items.**
- ☑ **Without markings, these items won’t be considered valid.**
- ☑ **Thinner is strictly banned inside the main event premises.**

Items to be marked with college name Initials:

- Driver’s Helmet (B.5.1)
- Arm Restraint (B.4.3)
- Driver’s Suit (both Upper and Lower Garments, for teams using split Driver’s Suit B.5.4.3 and B.5.4.4)

B.5.1 Helmet

All drivers must wear a properly sized motocross-style helmet with an integrated (one-piece composite shell) chin/face guard.

All helmets used in BAJA SAEINDIA® competitions shall meet the requirements of the ratings: Snell M2015, Snell M2020, ECE R22-05, SA 2005, British Standards Institution BS 6658-85 types A or A/FR. Any helmets not meeting these standards are explicitly prohibited.

- Do not rely on salespeople to determine if a helmet is Snell-rated.***
- Check for the Snell sticker under the foam liner of the helmet.***
- DOT, ISI, and DOT+ISI rated helmets are not allowed.***
- This rule has no exceptions, and it will be strictly enforced. Helmets certified to other rating systems not specified above may not be worn.***



Figure B- 43: Driver's Helmet

- ❑ **Some Motocross helmets have extended chin guards that will not contact the required neck collars when the head is flexed forward. This combination of helmet/collar systems is prohibited.**
- ❑ **Any non-specification helmets will be confiscated by the TEJ for the duration of the event. At the close of the endurance race, all confiscated items will be available for pick up.**

B.5.2 Eye Protection

B.5.2.1 Type

All drivers shall wear motocross-style goggles with a full-circumference elastic band that wraps completely around the driver's helmet. "Quick Straps" or other quick-release systems are explicitly prohibited.

B.5.2.2 Lens Protection

All goggles used by drivers must have tear-off or roll-off lens protectors. These tear-offs or roll-offs are used to ensure the driver has an unobstructed vision through their goggles. Teams must present their goggles and properly installed tear-offs or roll-offs at tech inspection. Teams without tear-offs or properly functioning roll-offs are subject to being black flagged.



Figure B- 44: Eye protection

B.5.3 Neck Support

B.5.3.1 Certification

All drivers must wear a neck support/neck collar. The neck support must be a full circumference (360 deg.) and SFI 3.3 rating. Horseshoe collars are not allowed. Simpson, RCI, G-force, Deist, or Leaf Racing Products supply neck collars that meet this requirement. Refer to the link below for a list of approved manufacturers for SFI 3.3 rated driver's accessories,

[SFI 3.3 Manufacturers List \(sfifoundation.com\)](http://sfifoundation.com)

The support/collar must be in overall good condition and show no signs of wear or other injurious defects. The support/collar must bear the appropriate dated labels, and on Jan 1st of the competition, the year is no more than three years old.

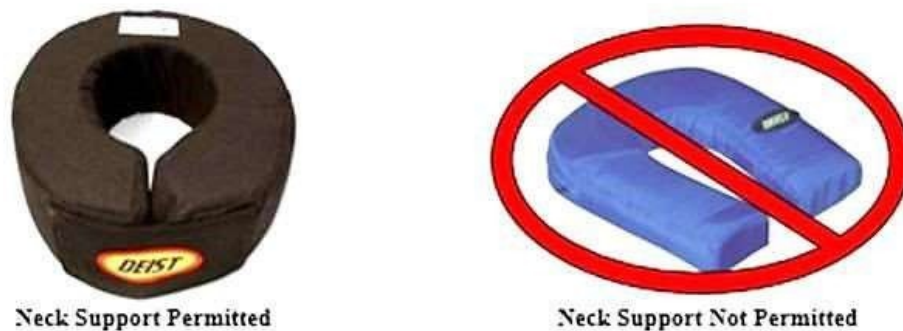

Figure B- 45: Driver Equipment, Neck Restraint

B.5.3.2 Expiration

In December of 2016, SFI updated the design and format of neck support/collar expiration tags.

Manufacturers are permitted to use old tags until their supply runs out. BAJA SAEINDIA® permits the use of arm restraints with the old and the new tag design, provided:

For old style tags: On April 1st of the competition year, harnesses shall be no more than three (3) years old.

For new style tags: Support/collar with expiration tags bearing a "Valid Until" date that is on or after the last day of the current competition.

See Figure B-32 for more information.

Manufacturers are required to ensure they have labeled the support/collar with a date of manufacturing. The date tag may be separate from the SFI tag.

B.5.4 Clothing

Teams are allowed to use two-piece or single-piece driver suits complying with rulebook section B.5.4.3 and B.5.4.4

B.5.4.1 Gloves

Drivers shall wear gloves to protect their hands. Durable, abrasion-resistant gloves are required.

B.5.4.2 Shoes

Drivers shall wear socks and shoes.

B.5.4.3 Upper Garments

Drivers shall wear a fire-resistant shirt. The shirt must have a factory label showing an SFI 3.2, SFI 3.3, SFI 3.4, FIA 8856-2000 fire-resistant rating. Refer to the link below for a list of approved manufacturers for SFI-rated Driver's Suits:

[SFI 3.2A Manufacturers \(sfifoundation.com\)](http://sfifoundation.com)

B.5.4.4 Lower Garments

Drivers must wear fire-resistant pants/suits having an SFI, FIA, NFPA 2112 fire-resistant rating.

Refer to the link below for a list of approved manufacturers for SFI-rated Driver's Suits,

[SFI 3.2A Manufacturers \(sfifoundation.com\)](http://sfifoundation.com)

B.5.4.5 Combustible Material

Jerseys, gloves, socks, or other garments made from nylon or any other synthetic material which will melt or combust when exposed to open flame or extreme heat, are explicitly prohibited from use during competition.

DRAFT

ARTICLE B.6: FUEL (hCNG Gas Layout) SYSTEM & VEHICLE INTERFACE COMPONENTS

B.6.1 Function

The main function of Fuel System is to ensure safe supply of CNG from CNG tank to combustion chamber for ensuring proper combustion.

The Bill of Material not limited to may consist of following:

Note:

- The details about hCNG Gas & Layout will be separately released on BAJA SAEINDIA Forum & Website as an when required.
- Atul Auto & Advantek will be providing the Vehicle level interface components to the teams.

Sl. No.	Part Description	Veh. Manufacturer
1	Low Pressure Hose (regulator to filter)	OEM
2	CNG Regulator with shut off valve	OEM
3	High pressure pipe, end connectors & Sensors	OEM
4	Hose Idle Air Control Valve to Clean Side Hose	OEM
5	Gasoline Fuel lines	OEM
6	Radiator & Hoses for cooling circuit	OEM
7	Recovery Tank	OEM
8	CNG Cyl, Valve, Pressure Gauge, Filler Valve, Micro Switch, & Fuel Indicator	OEM
9	Air Filter Hoses (Clean Side & Dirty Side)	OEM
10	CNG Filter +Damper	OEM
11	Sensors on gear box (vehicle speed sensor, etc.)	OEM
12	Accelerator Pedal / Hand operated throttle Unit	OEM

Sl. No.	Part Description	Veh. Manufacturer
13	Clutch switch	OEM
14	CAN bus	OEM
15	Instrument cluster with MIL, GP,WIF, System Service	OEM
16	OMS mtg. bkt.& breather out hose to intake side	OEM
17	3 way dumb Switch for fuel Selection	OEM
18	Petrol Solenoid and Petrol Switch	OEM
19	Muffler Assy & Tail Pipe of EATS	OEM
20	Engine Wiring Harness	OEM

ARTICLE B.7: VEHICLE CONTROLS

B.7.1 Brake System

The vehicle must have a primary hydraulic braking system that acts on all wheels and is operated by a single-foot pedal. The pedal must directly actuate the master cylinder through a rigid link (i.e., cables are not allowed). The braking system must distribute its action appropriately among axles. The action of the service braking system shall be distributed between the wheels of the same axle symmetrical to the longitudinal plane of the vehicle. The Brake system must achieve the prescribed 4 wheels locking within stopping distance (as a reference) specified in the dynamic test, without any abnormal noise, vibration, or juddering.

The brake system must be capable of locking and sliding all wheels, both in a static condition as well as at speed on pavement and on unpaved surfaces. Brake pedals shall be fabricated or machined from steel or aluminium and be designed to withstand a minimum brake pedal force of 450 lbf (2000 N).

 **Teams are advised to go through additional inputs for brakes design put up as an annexure labeled "GENERAL RECOMMENDATIONS FOR BRAKES DESIGN"**

B.7.1.1 Independent Circuits

The braking system must be segregated into at least two (2) independent hydraulic circuits such that in case of a leak or failure at any point in one system, effective braking power shall be maintained on at least two wheels. Each circuit brake system shall be designed to achieve a minimum 50% prescribed dynamic performance requirement.

Each hydraulic circuit must have its separate fluid reservoir either through physically separate reservoirs or by the use of a full-height dam in an OEM-style reservoir.

B.7.1.2 Brake Location

The brake(s) on the driven axle must operate through the final drive. Inboard braking through universal joints is permitted. Braking on a jackshaft through an intermediate reduction stage is prohibited.

B.7.1.3 Cutting Brakes

Hand or feet operated "cutting brakes" are permitted provided section B.7.1 is also satisfied. A primary brake system must be able to lock all four wheels with a single foot. If using two separate pedals to lock two (2) wheels apiece; the pedals must be close enough to use one foot to lock all four wheels.

Any brakes, when actuated, shall cause the brake light to illuminate.

B.7.1.4 Brake Lines

All brake lines shall be securely mounted to the vehicle and not projected below the vehicle frame or suspension components.

All brake lines shall be routed and oriented such that they are not pinched by steering or suspension parts, nor engaged with sharp edges.

All brake lines shall have a full range of motion within the steering and suspension system. IS 7079 compliance flexible Hydraulic Brake hose assembly, must be used to cater relative movements of steering and suspension system and any other.

Teams are recommended to use Bundy tube where there are no relative motions of components in the circuit routing, this is to minimize the volume expansions in tubes.

At no time shall the brake lines be loaded in tension or become engaged with the vehicle's tires and wheels.

All brake lines shall be designed for the pressures expected in the braking system and be chemically compatible with the brake fluid as per IS 8654.

No brake line may be constructed of plain, plastic tubing.

B.7.1.5 Brake Pedal

Teams are recommended and advised to operate the brake pedal on the right foot, which requires the pedal to be placed to the right side of the steering column. This is a recommendation made considering the requirement of adequate foot pressure to be applied on the brake pedal for effective braking.

 **For use of the brake pedal and accelerator pedal on the same side (right side), There must be a minimum of 40 mm clearance between both the pedals. It is recommended that the driver does not use the brake and acceleration pedal simultaneously.**

B.7.2 Throttle System

The vehicle's throttle system shall be capable of fully actuating the throttle arm to full throttle (100%) on the engine and return to idle (0% throttle) when released. The throttle shall remain in the as-inspected condition for the duration of the event. Re-inspection is available by appointment with Briggs and Stratton at the event site. "Throttle-by-wire" or other electronic throttle controls are explicitly prohibited.

B.7.2.1 Accelerator Pedal

Only mechanical, pedal (foot) operated throttle controls are allowed. The throttle pedal shall actuate a throttle cable.

Foot pedals shall be positioned to avoid entrapment of the driver's foot when in any position. Mechanical extensions such as thick pads or blocks may not be attached to the pedal or the driver's feet.

Accelerator Pedal should be actuated by right foot only.

B.7.2.2 Pedal Stop

A substantial, mechanical, wide-open throttle stop must be mounted at the pedal. Body panels or other flexible materials are explicitly prohibited.

B.7.2.3 Throttle Cable

The throttle cable must be covered (sheathed or jacketed) from the forward mounting point in the cockpit and the vehicle firewall.

Throttle cables may be of "bicycle style" construction where the cable operates only in tension. Throttle cables may be of "aircraft style" construction where the cable is capable of push-pull (tension-compression) operation.

Severe redirections of the throttle cable at the engine or the throttle pedal causing binding or restricted function are prohibited. Redirections more than 15 degrees from the cable jacket centerline are not recommended.

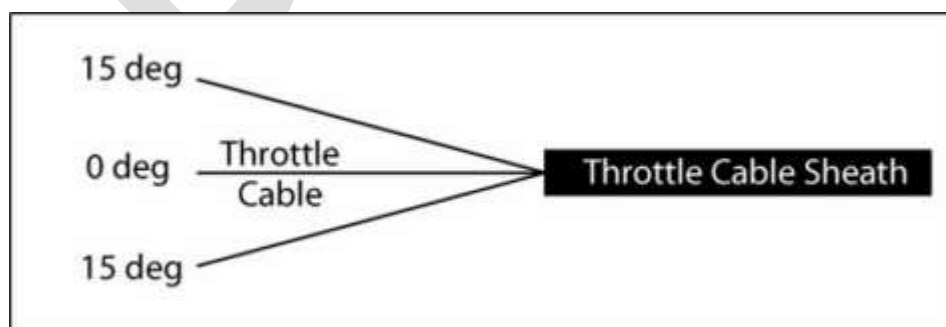

Figure B- 53: Throttle Cable Exit Angle

B.7.2.4 Fail-Safe

All throttle controls shall be designed to return to the idle stop in the event of a failure. The throttle cable must be covered (sheathed) between its forward mounting point and the firewall to prevent debris ingress.

B.7.3 Other Control Systems

B.7.3.1 Compressed Gas Systems

Compressed gas systems are allowed for vehicle control systems. For example, a compressed gas system may be used to change transmission states (i.e., shift gears). Compressed gas systems are explicitly prohibited from providing increased engine power, cooling, and/or vehicle propulsion. The TEJ reserves the right to require additional protections or safety features on any compressed gas system.

B.7.3.1.1 Gas Composition

Compressed gas systems shall operate only with non-flammable or non-oxidizing gases. Air, nitrogen, and carbon dioxide are examples of acceptable gases. Methane, propane, and oxygen, are examples of unacceptable gases.

B.7.3.1.2 Gas Storage

Compressed gases shall be stored in containers meeting the following requirements.

- Compressed gases shall be stored in cylinders (tanks) of propriety manufacture, designed and built for storage and operating pressures, certified by an accredited testing laboratory in the country of the cylinder's origin, and be labeled or stamped appropriately.
- The compressed gas cylinder shall be located within the roll envelope and aft of the RRH, protected from rollover and collision damage.
- The compressed gas cylinder shall be protected from damage from failed rotating equipment.
- The compressed gas cylinder shall be securely mounted to the vehicle frame, engine, or transmission, and oriented such that the longitudinal axis of the cylinder is not in line with the driver.
- The compressed gas cylinder shall be insulated from excess heat such as the engine or exhaust.

B.7.3.1.3 Gas Service Equipment

All service equipment in the compressed gas system shall meet the following requirements.

- Pressure Regulators shall be rated for compressed gas service and be mounted directly to the compressed gas cylinder.
- Any fittings or connectors in the compressed gas system shall be rated for the pressures and temperatures experienced downstream of the pressure regulator.
- Any hoses, tubing, or other conveyances in the compressed gas system shall be rated for the pressures and temperatures experienced downstream of the regulator.
- Any gauges, indicators, or other instrumentation in the compressed gas system shall be rated for the pressures and temperatures experienced downstream of the regulator.

B.7.3.1.4 Compressed Gas Mechanisms

All compressed gas mechanisms, including cylinders, slides, actuators, or motors shall be rated for the pressures and temperatures experienced downstream of the regulator.

ARTICLE B.8: COCKPIT

B.8.1 Design Objective

The cockpit shall be designed to protect the driver and permit easy egress in an emergency.

B.8.2 Cockpit Egress

Any drivers must be able to egress (exit) on either side of the vehicle within five (5) seconds. Drivers tested for egress time shall begin with all safety gear and be fully seated and secured in the vehicle with their hands on the connected steering wheel.

Egress time is timed from the instant either one hand of the driver is removed from the steering wheel to the instant the driver is clear of the vehicle with both feet on the ground.

The TEJ will select one or more drivers to perform the cockpit egress test.

Drivers unable to demonstrate successful egress will have their driver status revoked.

Each team is required to have a minimum of two designated drivers.

B.8.3 Firewall

All vehicles shall have a firewall separating the cockpit from the engine and fuel tank compartments. The firewall shall be constructed of metal, at least 0.50 mm (0.02 in.) thick. The firewall shall be mounted in the plane of the RRH and cover the area between the ALC and BLC.

Multiple metal panels may be used to form the firewall, provided there are no gaps between the joints. Select cut-outs are allowed for control cables, brake lines, electrical cables, and 4WD/AWD components provided the cut-outs have proper grommets and sealing to prevent fuel from leaking into the cockpit.

Large cut-outs in the firewall are explicitly prohibited. Large cut-outs include those for CVT ventilation and other similar items. Air intakes may not penetrate the firewall and must remain within the roll cage envelope. Cut-outs for drivetrain components are permitted.

Note Updated: Use metal fasteners only. Plastic screws/snap-fit plugs/Zip ties are not acceptable.

B.8.4 Front or Mid-Engine Vehicles

If the mounting points of the engine are completely forward of the RRH, then a firewall is not required to cover the area within the plane of the RRH and between the LCs of the RRH. If the mounting points of the engine are completely forward of the RRH, the following requirements must be met:

- The fuel tank shall be enclosed in a sealed container that prevents fuel from leaking in the event of a fuel tank failure.
- Splash shields must prevent fuel from being poured anywhere in the cockpit area during fueling.
- The engine shall be completely enclosed, and the enclosure shall protect the driver in the event of an engine failure. The engine enclosure shall be metal and meet the requirements of Article 9 - Powertrain Guards.
- Engine enclosures must prevent fuel from spilling into the cockpit should the vehicle be involved in a collision or roll-over.
- All engine compartment venting shall be directed away from the cockpit.
- The driver must be able to egress from both sides of the vehicle.

- The engine exhaust shall not exit in the direction of the driver and shall be shielded from contact by track workers and competition officials.
- A panel, 300 mm x 300 mm (12 in. x 12 in.), shall be affixed to the vehicle in the plane of the RRH, on the right side of the driver's head, and above the shoulder level of the tallest driver. This panel shall be used to affix the Technical Inspection sticker and shall be easily viewed by track workers and competition officials.

B.8.5 Body Panels

The cockpit must be protected with body panels that completely cover the area between the LFS and the SIM. No gaps can exist that are larger than 6.35 mm (0.25 in) and will be checked with a 6.35 mm (0.25 in dowel rod). These panels must be made of puncture-resistant material, including plastic, fiberglass, metal, or similar material. They must be designed to prevent debris and foreign object intrusion into the driver compartment. The panels must be mounted securely to the frame using sound engineering practices (cable ties or hook-and-loop fastening is not acceptable).

 **Quick disconnect or easily accessible fasteners for body panels are recommended and facilitate a faster technical inspection process.**

B.8.6 Skid Plate

The cockpit must be fitted with a skid plate (belly pan) over the entire length of the cockpit so that the driver cannot contact the ground and is protected from debris while seated normally. Skid plate material must be metal, fiberglass, plastic, or similar material. They must be designed to prevent debris and foreign object intrusion into the driver compartment. Expanded metal, fabric, or perforated panels are not allowed.

Skid Plates shall be constructed of one or both of the following required materials:

- Steel, at least 1.5 mm (0.06 in.) thick, meeting or exceeding the strength of AISI 1010 steel.
- Aluminium, is at least 3.0 mm (0.12 in.) thick, meeting or exceeding the strength of 6061-T6 aluminium.
- Fiber/plastic or equivalent, at least 5 mm (0.19 in.) thick

 **The belly pan should withstand the load of the driver in all conditions.**

B.8.7 Shielding for Legs and Feet

B.8.7.1 Linkages

All steering or suspension links exposed in the cockpit shall be shielded with a sturdy, robust, metal cover. The shielding must prevent the driver's legs and feet from coming in contact, becoming entangled, or being struck during operation or a failure.

 **Quick disconnect or easily accessible fasteners for cockpit steering and suspension covers are recommended and facilitate a faster technical inspection process.**

B.8.7.2 Universal Joints

Universal joints in the steering or 4WD/AWD system near the driver's feet must be shielded or sealed such that the driver's clothes or feet may not become entangled in the joint.

Caution: Loose shoelaces can and have become entangled in universal joints and will hinder driver egress from the cockpit.

B.8.8 Fire Extinguisher

All vehicles shall be equipped with a charged and functional fire extinguisher in the event of a fire on the vehicle, in the paddocks, or on the track. All team members shall be familiar with the use and operation of fire extinguishers.

B.8.8.1 Rating and Required Features

All fire extinguishers for use on the vehicle shall be 1KG ABC DRY POWDER. All fire extinguishers for use on the vehicle shall be equipped with a manufacturer-installed dial pressure gauge. The dial pressure gauge shall be readily visible and indicate the unit has been properly charged. Each fire extinguisher shall be labeled with the college name and vehicle number.

B.8.8.2 Quantity

Each team shall have two or more fire extinguishers meeting the requirements above. One fire extinguisher shall be installed on the vehicle, and the remaining extinguishers shall serve as spares.

 **Both the fire extinguishers (one Spare and one fixed in the vehicle) must have the same size.**

B.8.8.3 Required Bracket

The only permitted fire extinguisher mounting brackets are the:

- Drake FIREX-MNT-DOR
- Drake FIREX-MNT-S-DOR
- Drake FIREX-MNT-DAG
- Drake FIREX-MNT-S-DAG

[Scott Drake FIREX-MNT-DAG Scott Drake Quick Release Fire Extinguisher Mount \(holley.com\)](http://holley.com)

 **It is recommended teams keep a spare mount available.**

B.8.8.4 Mounting

The fire extinguisher mounting bracket shall be mounted in the plane of the vehicle's RRH. The fire extinguisher mounting bracket shall be affixed to the RRH via steel tabs with a minimum thickness of 3 mm (0.125 in.) thick.

Mounting hardware shall be flat socket head cap screws with a countersink angle and head diameter matching the required Drake bracket. Hardware used to secure the bracket to the vehicle frame shall meet all requirements of Article 12, Fasteners.

The fire extinguisher shall be affixed to the mount via hose clamps. The hose clamp adjusters shall be installed so as not to interfere with the operation of the pull-knob on the Drake bracket. The hose clamp adjusters and protruding material shall be installed so as not to snag on the clothing of a driver during vehicle egress.

B.8.8.5 Location and Clearance

The fire extinguisher shall be positioned on the right side of the driver, within the cockpit such that the fire extinguisher is completely below the driver's eye level, and the top half of the fire extinguisher is above the SIM. The fire extinguisher shall be easily accessible by track workers.

The pull knob of the required bracket shall be easily actuated. To facilitate this, a minimum radial clearance around the pull knob of 64 mm (2.5 in.) is required. It is understood the area aft of the pull knob will be less than 64 mm (2.5 in.) due to the design of the bracket. See figure B-54.1 for further clarification.

- Radial clearance is the unoccupied space between the edge of the pull knob and the nearest obstruction. The measurement is not made to the center of the pull knob.



Figure B- 54.1: Fire Extinguisher, Diagram of Clearance around Pull Knob (green)



Figure B-54.2: Fire Extinguisher Mounting, Do's and Don'ts

ARTICLE B.9: POWERTRAIN GUARDS

B.9.1 Powertrain Guards and Finger protection

All rotating powertrain components (CVTs, Gears, Sprockets, Belts, and Chains) shall be shielded to prevent injury to the driver, track workers, or bystanders. Guards shall protect against the hazardous release of energy should rotating components fail. Finger protection shall also protect against fingers, loose clothing, or other items from being entangled in the rotating components (pinch points). Universal joints, CV joints, hubs, rotors (Not applicable for Inboard Brakes), wheels, and bare sections of shafts are exempt from the requirements of B.9.1 and B.9.2.

B.9.2 Hazardous Release of Energy (HROE)

Powertrain guards and shields protecting against the hazardous release of energy shall extend around the periphery of the rotating components (chains, gears, sprockets, belts, and CVTs) and have a width wider than the rotating part the guard is protecting.

- This means the entire periphery of the primary CVT pulley, not just the belt width.

All powertrain guards shall be constructed of one or both of the following required materials:

- Steel, at least 1.5 mm (0.06 in.) thick, meeting or exceeding the strength of AISI 1010 steel.
- Aluminium, is at least 3.0 mm (0.12 in.) thick, meeting or exceeding the strength of 6061-T6 aluminum.

Holes and/or vents in the portion of the powertrain guard surrounding the rotating components are acceptable provided that in the event of a powertrain failure, no parts can escape. No direct path shall exist tangent to any rotating components.

Powertrain guards shall be mounted and secured with sound engineering practices to resist vibration and shock.

B.9.2.1 Belt, Gear, and Chain Drives

HROE guards shall be a continuous metal band extending around the entire periphery of the drive assembly. The width of the continuous metal band shall be wider than the entire width of the rotating component. FIGURE B 55

HROE guards may contain ventilation ports along the path of the guard. Ventilation ports shall be constructed from the same material as the guard, be arranged in such a manner that no radial or tangential path exists for flying debris to exit the ventilation port. The ventilation port shall also be constructed to not allow a searching finger to contact the rotating components when the ventilation tube is removed.

B.9.2.2 Hydraulic Systems

Hydraulic systems shall protect against hazardous release of energy. Hydraulic hoses shall have jacketing that meets HYDRAULIC SPEC. Hydraulic relief valves shall safely vent to the tank and away from people.

Any hydraulic hoses running through the cockpit to the front axle shall be protected from damage by a driver entering or exiting the vehicle. Protection shall be made by a sturdy, robust cover. Note that hydraulic systems shall meet the requirements of B.2.6.1 - Hydraulic.

B.9.2.3 Axle shafts

Axle shafts and associated CV or universal joints forward of the firewall directly connecting the front wheels/uprights to the front differential do not require specific guarding for track workers and bystanders, but shall be separated from the driver and cockpit by way of methods meeting requirements of B.8.5 - Panels and B.8.6 - Skid Plate.

All other universal joints, CV joints, or similar shall be protected with HROE guarding extending 25.4 mm (1.0 in.) axially beyond the extent of the joint.

B.9.3 Pinch Points and Entanglement

Rotating parts in the powertrain system rotating faster than the final drive shall be guarded on all sides, in addition to the guard around the periphery. Guarding for pinch points shall prevent small, searching fingers from getting entrained in any rotating part. Flexible, non-rigid, fabric coverings such as "Frog skin", Ceconite, and neoprene are unacceptable for use as finger guards. Powertrain covers fastened with adhesive, ratcheting tie-downs, and other temporary methods are explicitly prohibited. All powertrain covers shall have resilient and durable mountings with easily accessed and actuated fastening devices.

A complete cover around the engine and drivetrain is an acceptable shield for pinch points but does not relieve the requirement for the release of hazardous energy.

This is also applicable to the Front differential casing and other rotating components on the front side of the cockpit.

 **Inboard Braking rotors should meet the rules of the powertrain Guard and should prevent the unintentional contact of hands with the rotor. Integrated CVT casing and brake rotor casing can be used.**

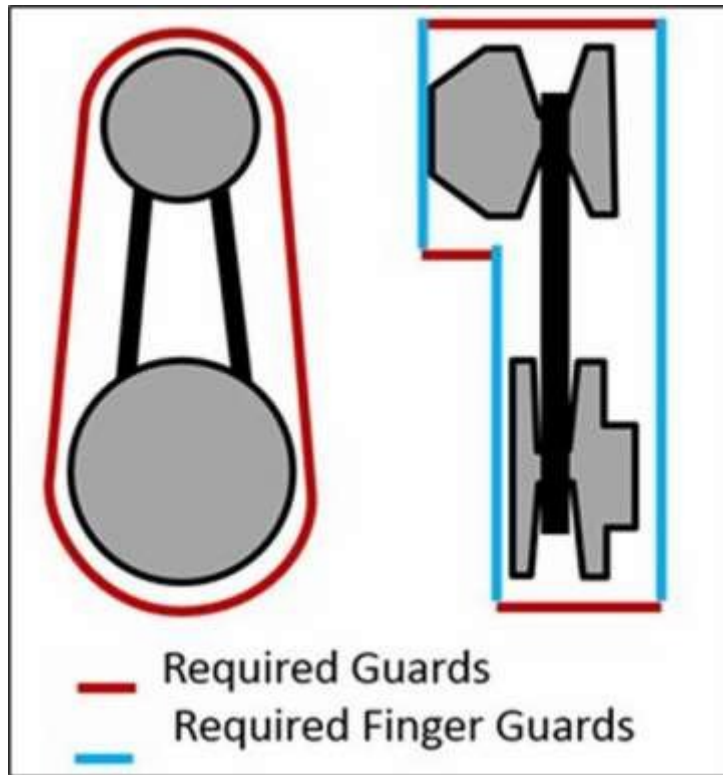

Figure B- 55: Powertrain Guard Extents



Figure B- 56: Powertrain Guard Example

- ☑ All guards, whether Chain-drive or CVT, must maintain a clearance of at least 15mm from any nearby roll cage member or suspension component. This is applicable to the Front differential & steering components in the front side of the cockpit.

B.9.4 Stock, OEM Guards

Factory stock guards (OEM) shall meet the requirements in this article. Any OEM, factory stock guards that are not modified are exempt from the requirements in rules B.9.1 - Powertrain Guards and B.9.2 - Hazardous Release of Energy. OEM covers must still meet the requirements of B.9.3 - Pinch Points and Entanglement in way of the vent.

B.9.5 Powertrain Breather / Vent System

Gearboxes and transmissions with a breather/vent system shall prevent loss of fluid in a rollover or by thermal expansion. This may be achieved with a vent tube or other suitable means.

Any vent line connected to a gearbox or transmission shall be constructed from a material suitable for transporting oil used in the gearbox or transmission. At all times, the vent line shall maintain a clearance of at least 100 mm (3.94 in.) from the exhaust, be properly secured without being pinched, and shall terminate inside a non-primary frame member. The hole shall not be a through-hole and is not required to be sleeved following B.3.6.1.1 – Sleeved Joints. If the hole is larger than 8.0 mm (5/16 in.) then a reinforcing plate (scab plate) is required around the hole.

Exception: Vent lines more than 457 mm (18.0 in) from the engine or exhaust are not required to terminate inside the frame member. The entire vent line must be greater than 457 mm (18.0 in.) from the nearest engine or exhaust component to qualify for this exception.



Figure B- 57: Example of a gearbox vent tube terminating inside a frame member.

B.9.6 Drive Shafts

Longitudinal drive shafts connecting the front and rear gearboxes/differentials in a 4WD/AWD system may be a hybrid of powertrain guards and finger protection as described in this section.

Any universal joint, CV joint, or similar joint (all referred to as “joint” for this rule) in the driveshaft assembly shall be surrounded by powertrain guarding following B.9.2 - Hazardous Release of Energy. The driveshaft hoops shall be a minimum of 30 mm wide to either side of the joint or up to the mating gearbox/differential, whichever is closer.

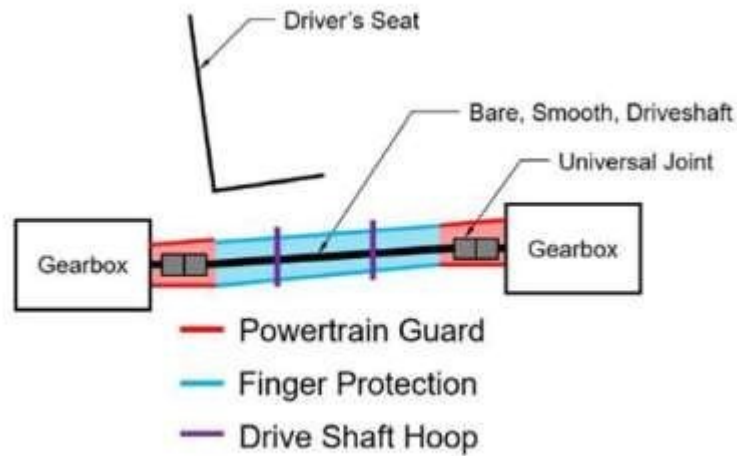

Figure B- 58: Driveshaft Guarding

The driveshaft will be constrained from failure via two drive shaft hoops, within 51 mm (2.0 in.) of the 1/3 length point and the 2/3 length point. Hoops should have minimal clearance to the driveshaft. The driveshaft hoops shall be 25 mm (1.0 in.) wide, meeting the same material requirements as B.9.2 - Hazardous Release of Energy, and shall be mounted by welding or fasteners.

If the used flanges or bearings that falls in the above specified lengths that can be itself considered as a support for the Drive shafts. Irrespective of any case, the guards used for protecting the driveshaft must be rigidly fastened and secured in place with additional hoops mounted to be made rigid.

Drive shafts on either side of the skid plate (driver’s side or the ground side) shall meet the same requirements. The skid plate may be considered part of the finger protection.

Chain drives in the cockpit shall meet the existing rule B.9.2.1 - Hazardous Release of Energy.

Any hydraulic hoses running through the cockpit to the front axle shall be protected from damage by a driver entering or exiting the vehicle. Protection shall be made by a sturdy, robust cover. Note that hydraulic systems shall meet the requirements of B.2.6.1 - Hydraulic.

ARTICLE B.10: ELECTRICAL SYSTEM

A minimum electrical system comprising of at least two kill switches, a brake light, a brake switch, battery, and associated wiring is required. The vehicle's electrical system shall be designed and constructed following best engineering and electrical practices. Brake lights shall operate regardless of the kill switch setting and shall always be powered and functional all the time.

B.10.1 POWER SOURCES

B.10.1.1 Batteries (Auxiliary Battery)

Any electronics parts or items on the vehicle can now simply be battery powered, without the horsepower cost of running the alternator. Any battery used for safety appliances (brake light, reverse light, reverse alarm) shall have the sufficient electrical capacity to last the entire length of the endurance event.

B.10.1.1.1 Mounting

All batteries shall be mounted with sound engineering practices and not come loose during normal operation, a collision, or rollover. Battery terminals shall be insulated and protected against an electrical short.

B.10.1.1.2 Sealed Batteries

All batteries must be factory sealed and maintenance-free. Batteries shall be incapable of being opened or serviced and not leak in the event of a collision or rollover.

B.10.1.2 Engine Alternator

Only approved engine alternators may be used. See rule B.2.7.15 - Alternator for further information.

B.10.1.3 Solar Panels

Solar panels are permitted to recharge onboard batteries.

B.10.2 Wiring and Connectors

All vehicle wiring and connectors shall be cleanly and neatly installed. Wiring shall be routed away from sources of excessive heat, abrasion, chafing, and possible short circuit. Wiring shall be installed and routed such that it does not become a hazard to cockpit egress.

B.10.3 Kill Switches

B.10.3.1 Quantity

Each vehicle shall be equipped with a minimum of two (2) kill switches.

All the Kill Switches must be PUSH TO KILL type.

B.10.3.2 Required Switch

The vehicle shall be equipped with one or more of the following required switches:

- Polaris Part 4013381 or 4019114
- Ski-Doo Part 01-171 (<http://www.mfgsupply.com/01-171.html>)
- WPS 27-0152
- WPS 27-0154

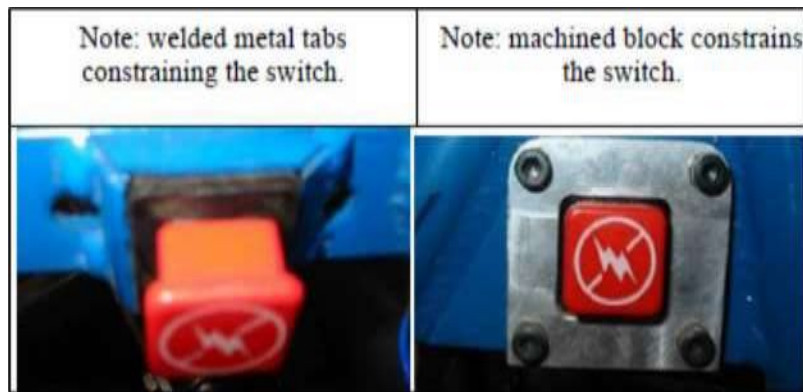

Figure B- 59: Allowed Kill switch type



Figure B- 60: Prohibited Kill switch type

- Older versions of the approved switches are allowed, provided the purchase date is less than 3 years at the time of competition.

B.10.3.3 Location

B.10.3.3.1 Cockpit Switch

A minimum of one cockpit kill switch is required as defined by this rule. Additional cockpit kill switches are permitted provided the switch meets rule B.10.3.2 - Required Switch.

The cockpit kill switch shall be mounted on the Left or Right side of the driver, along the SIM or near the dash panel, within reach of a driver's palm, provided that the driver is properly secured in the vehicle with all restraints (including arm restraints).

No other push button switches should be mounted near the Cockpit kill switch.

- The switch must not be placed close to the driver's elbow and knee. The switch must be positioned ahead of the driver's torso. Teams should ensure that the kill switch mount does not hinder cockpit egress. Proper knee and elbow clearances are to be maintained as per Clause B.14.3.

B.10.3.3.2 External Switch

One of the required kill switches shall be located within easy access to track workers on the right side of the vehicle, aft of the plane of the RRH, and forward of the right FABUP. The external kill switch shall be generally perpendicular to the firewall (± 15 deg), below frame point BR, and no further than 180 mm (7.0 inches), dimension "Z" in Figure B-61, below frame point BR, and shall be mounted on a tab connected directly to the RRH. The external kill switch shall not be recessed more than 51 mm (2.0 inches) from the outside edge of the RRH tube.

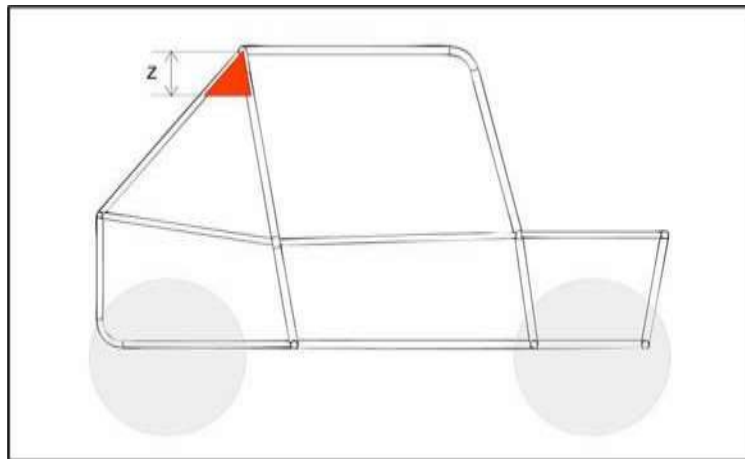

Figure B- 61: Engine Kill Switch Mounting Position

B.10.3.4 Mounting

All kill switches shall be rigidly mounted to the vehicle frame with unobstructed access to the switch. All engine kill switches shall be free and clear of sharp edges or other hazardous conditions to track workers or the driver. All switches shall be mechanically fastened to the frame. Adhesives are explicitly prohibited. Any fasteners used to mount an engine kill switch shall meet the requirements of Article 12 - Fasteners.

Exception: Rivets are acceptable fasteners for fastening kill switches to the mounting tab.

 **Both the kill switches shall be located within the roll envelope and protected from rollover and collision damage.**

B.10.4 Signaling

B.10.4.1 Brake Light

All vehicles are required to have a functional brake light to signal to other drivers the vehicle is stopping or slowing down. The brake light is strictly to be RED in colour and must be visible in the daytime (in any weather condition) for 20 meters. The wattage of the Brake light bulb should be as per AIS standard.

B.10.4.1.1 Required Brake Light

Only the following brake lights are permitted along with Indian OEM Brake lights. Brake lights not listed and apart from OEM are explicitly prohibited. Modification of the brake light from the OEM design is explicitly prohibited. All brake lights shall be configured to be fully illuminated when the brakes are applied, and completely extinguished with the brakes are released.

- Polaris Part # 2411450
- Polaris Part # 2411099
- Polaris Part # 2411092-432
- Haul-Master – Part # 93263
- Command Electronics Part # 003-6018R
- Command Electronics Part # 003-6016
- Haul-Master – Part # 93263
- Command Electronics Part # 003-6018R
- Command Electronics Part # 003-6016

- ☑ **Brake light must have homologation marking engraved on the lens/housing part of the lamp. (Not allowed with stickers pasted). An original bill copy would be needed for verification at the event site. In the case of SAE DOT ratings, DOT SAE XXXX markings are also acceptable. The most common lamps available in India would be with E4 and E9. (They are acceptable).**



Figure B-62: Brake Lights

B.10.4.1.2 Location and Orientation

The vehicle brake light shall have a resilient and durable mount (with lock nuts if necessary) and be positioned at a minimum of 1000 mm (39.4 in.) above the ground. The vehicle brake light shall be oriented to be visible to trailing vehicles and shine parallel to the ground or at a slightly downward angle. Brake lights angled (aimed) above a horizontal plane are not permitted.

B.10.4.1.3 Brake Light Switch

The brake light shall be activated only by a hydraulic pressure switch installed in the brake hydraulic lines. Each independent hydraulic brake circuit must be equipped with a hydraulic pressure switch. Cutting brakes are required to activate the brake light by way of a hydraulic pressure switch.

- ☑ **Teams can use a mechanical pressure switch for activating brake lights ensuring adherence to installation guidelines, proper connections, and checks to avoid leakages. Brake pressure switches of 2-wheelers are strictly prohibited.**

B.10.4.2 Reverse Light

Vehicles with reverse gear shall be equipped with reverse light. The reverse light shall illuminate when the vehicle is shifted to reverse gear and is extinguished when the vehicle is shifted out of reverse gear. The wattage of Reverse light bulbs should be as per AIS standard.

B.10.4.2.1 Specification

Reverse lights shall be marked with an SAE "R" on the lens of the reverse light and be of an LED design, equal to or exceeding the SAE standard J759. Indian OEM Reverse lights are also permitted along with the SAE Rated Reverse Light.

Reverse light must have homologation marking engraved on the lens/housing part of the lamp. (Not allowed with stickers pasted). An original bill copy would be needed for verification at the event site. In the case of SAE DOT ratings, DOT SAE XXXX markings are also acceptable. The most common lamps available in India would be with E4 and E9. (They are acceptable)

- ☑ **LED strips for reverse light are strictly prohibited.**

B.10.4.2.2 Location and Orientation

The reverse light shall have a resilient and durable mount and be positioned at a minimum of 700 mm (27.6 in.) above the ground. The reverse light shall be oriented to be visible to trailing vehicles and shine generally parallel to the ground.

B.10.4.3 Reverse Alarm

Vehicles with reverse gear shall be equipped with an audible reverse alarm. The reverse alarm shall sound when the vehicle is shifted to reverse gear and silenced when the vehicle is shifted out of reverse gear.

B.10.4.3.1 Specification

Required reverse alarms shall be rated to meet the SAE standard J1741 or J994. Indian OEM reverse alarms are also permitted along with the SAE Rated Reverse alarm.

B.10.4.3.2 Location

Required reverse alarms shall be mounted to the vehicle frame aft of the plane of the RRH.

B.10.5 Instrumentation

Vehicles may be equipped with instrumentation to provide operational or performance information to the driver. All vehicle instrumentation must be included in the cost report.

B.10.6 Data Acquisition

Vehicles may be equipped with data acquisition (data logging) systems. Data acquisition systems providing live feedback to the driver or telemetry data to the team must be included in the cost report. Data acquisition systems not providing live data to the driver and/or telemetry data to the team may be excluded from the cost report.

B.10.7 Communication Systems

Teams are permitted to use radio-frequency (RF) communications systems. Any team using RF systems shall comply with Indian, state, and local regulations based on the location of the event. At no point may a team's RF systems cause harmful interference to the voice or data systems in service of competition officials or emergency responders.

B.10.7.1 Voice

Vehicles are permitted to use RF voice communications systems. RF Voice communication systems and equipment may be **excluded** from the cost report.

B.10.7.2 Data

Vehicles are permitted to use RF data communications systems. All RF data communications systems and associated equipment shall be **included** in the cost report.

ARTICLE B.11: TOW POINTS

B.11.1 General Requirements

Each vehicle must have towing hitch points at the front and rear, along its longitudinal centerline. These hitch points are used both for dynamic events and for vehicle recovery. Tow points must be attached to the vehicle frame and must allow for the transmission of both longitudinal and lateral towing loads. Towing loads will be imparted to the tow point by way of hook or clevis. Tow points shall have sufficient strength to serve as a vertical lift point for the vehicle.

B.11.2 Front Tow Point

Front tow points shall be constructed of tubular steel, not to exceed 31.75 mm (1.25 in.) and not less than 25.4 mm (1.0 in.) in diameter. Tubing thickness shall not be less than 0.89 mm (0.035 in.).

Front tow points shall be mounted no higher than the vehicle's SIM and not below the vehicle's LFS.

The front tow point shall be able to freely pass a gauge measuring 50.8 mm tall, 50.8 mm deep, and 203.2 mm wide (2.0 in. x 2.0 in. x 8.0 in.) behind the front tow point tube. See Figure B-62 for further information.

- ✔ **Front numbers may not interfere with tow-point.**
- ✔ **The front or Rear Bumper can't be considered as a hitch point. If tubes are being used, they must be made of primary members. In addition, there must be lateral constraints for the hook or clevis to be properly in place which is optimum for the effective transmission of vehicle loads while lifting. Note that a bumper must be a FIXED one and not a removable part and should be present from GO-NO-GO till the end of the event.**



Figure B- 62: Front Hitch Point Clearances

Examples of acceptable Front Hitches:



Figure B- 63: Acceptable Front Hitch Points

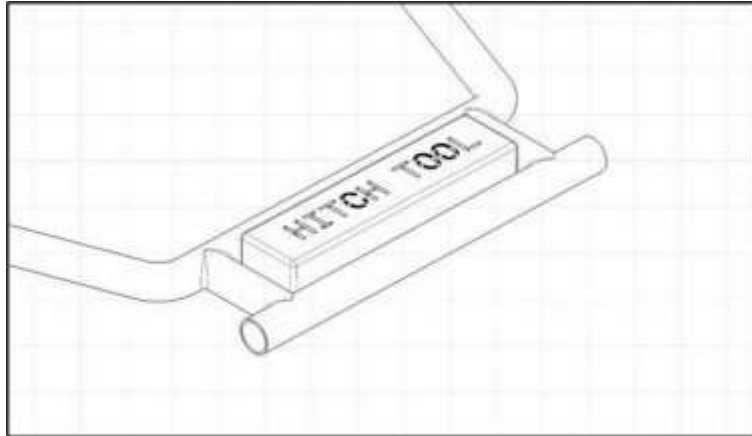

Figure B- 64: Tow Point, Inspection Tool Fitment

B.11.3 Rear Tow Point

Rear tow points shall be constructed from steel and meet the following requirements. See Figure B-66 for further information.

Dimension	Symbol	Minimum	Maximum
Tab Thickness	None	3.18 mm (0.125 in.)	9.5mm (0.375 in.)
Hole Diameter	D	25.4 mm (1.0 in.)	31.75 mm (1.25 in.)
Hole-to-Tube Offset	X	19.0 mm (0.75 in.)	25.4 mm (1.0 in.)
Edge Distance	R	15.9 mm (0.625 in.)	25.4 mm (1.0 in.)
Width at Frame Connection	Y	76.2 mm (3.0 in.)	Unrestricted
Material	None	Steel 1018	

Figure B- 65: Tow Point, Table of Tow Point Dimensions

Material for Tow-Hitch plate is strictly restricted to steel. Use of Aluminium is prohibited.

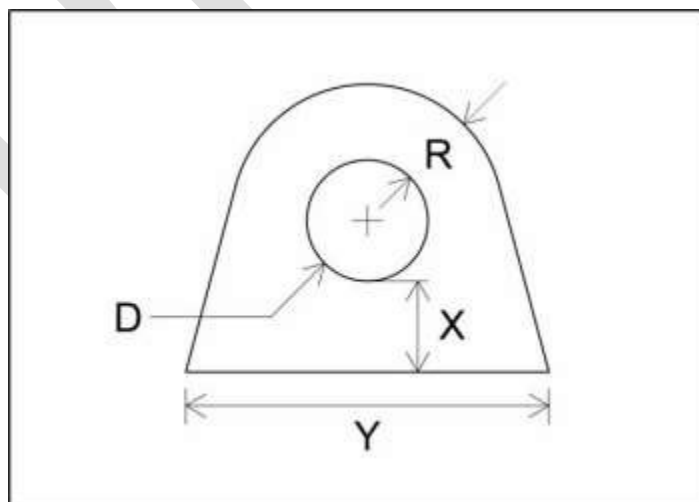

Figure B- 66: Tow Point, Rear Tab Dimensions

Rear Hitch Plate should be directly welded to the roll cage member. Latch-type rear hitch plates are not allow

B.11.3.1 Fixed Rear Tow Point

Fixed rear tow points shall be fully welded to the vehicle frame along the base line, dimension Y. The tab may be vertically or horizontally oriented.

B.11.3.2 Swivel Rear Tow Point

Swivel, or hinged, rear tow points shall be attached to the frame by way of a swivel mechanism. A swivel rear tow point may be horizontally or vertically oriented. The tabs for attaching the swivel mechanism to the frame shall be fully welded, a minimum thickness of 0.125 in thick, and have equal base line weld lengths totaling greater than or equal to dimension Y. Swivel pins shall be a graded fastener at least a 0.25inch diameter meeting the requirements of B.12.1 – Fasteners.

DRAFT

ARTICLE B.12: FASTENERS

B.12.1 Scope

Fasteners in the following vehicle systems shall meet the requirements of this article.

- Driver Harness
- Fuel System
- Fire Extinguisher
- Engine Kill Switches
- Steering, Suspension, and Brake System
- Battery and Powertrain mounts

B.12.2 Captive Fasteners

Fasteners shall be made captive by the use of the following:

- Nylon Locknuts
- Cotter Pins
- Safety Wire (for blind hole applications)

Lock washers and/or thread sealants do not satisfy the requirements of this rule.

B.12.3 Thread Projection

To provide for proper thread engagement in the lock nut, threaded fasteners shall have at least two (2) threads projecting past the end of the nut.

B.12.4 Grade

Threaded fasteners shall meet or exceed one or more of the following strength grades:

- SAE Grade 5
- Metric Grade 8.8
- AN/MS specifications

Below depicts bolt markings meeting or exceeding the requirements above.

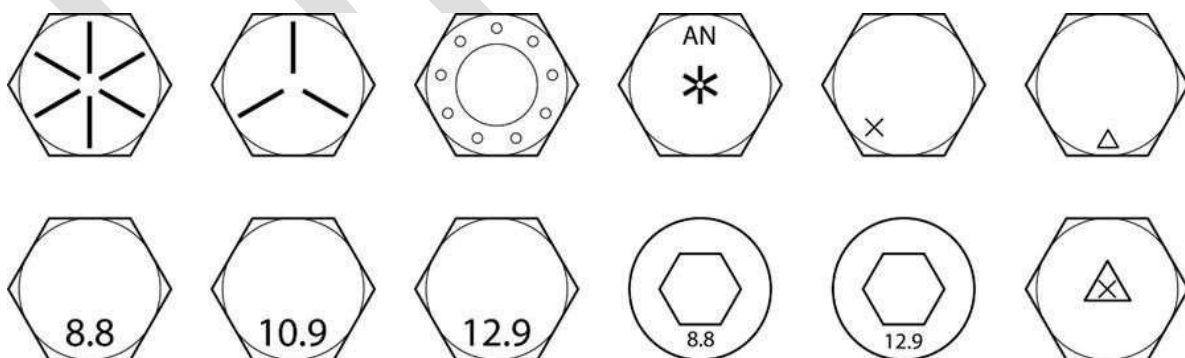

Figure B- 67: Fasteners, acceptable markings

B.12.5 Proof of Grade

For fasteners, without markings, as described above, proper documentation shall be supplied which requires a purchase receipt and manufacturer's specification (including markings) indicating the fastener strength exceeds or is equivalent to the requirements of B.12.4 - Grade.

 **Teams using fasteners with readily visible grade markings will reduce their time in technical inspection.**

B.12.6 Unmarked or Custom Fasteners

Any threaded fastener (threaded rod, eye bolts, titanium bolts, etc.) that is unmarked, or does not have any markings as listed, must be documented by one or both of the following:

- A purchase receipt and manufacturer's documentation indicating the fastener meets or exceeds Grade 5 standards for that size.
- Equivalency calculations with a purchase receipt or test data show that the fastener exceeds the strength of a Grade 5 fastener of the same size.

B.12.7 Modified Fasteners

Fasteners that have been modified in any way other than drilling for safety wire or shortening of the shank (threads) shall be proven to the TEJ to meet the requirements of this article.

ARTICLE B.13: VEHICLE IDENTIFICATION AND MARKINGS

B.13.1 Vehicle Number Assignment

Vehicle numbers shall be assigned as part of the final list of registered teams after the closure of the registrations. Assigned numbers shall be released on BAJA SAEINDIA Forum.

B.13.2 Transponders

For all BAJA SAEINDIA® competitions, a transponder system is used for timing and scoring. All teams participating in the BAJA SAEINDIA® competition are required to have two transponders mounted on their vehicle throughout the event. Vehicles must carry two functional, properly mounted, and fully charged transponders of the specified type. Vehicles without the specified transponders will not be allowed to compete in any event for which a transponder is used for timing.

 **Teams must register and mount two transponders on their vehicles so that in case of failure of one transponder data recorded by the other(functional) transponder can be used. The two transponders should be mounted 300 mm apart. Teams must ensure that the path between the transponder (or transponders) and the ground is unobstructed.**

 **Teams are allowed to use two same/different models of transponders provided they meet clause B.13.2.1**

 **It is the team's responsibility to get an active transponder subscription and charge the transponders adequately for them to last the entire duration of the endurance event (for 1 hour).**

B.13.2.1 Required Transponder

All vehicles must be equipped with two MYLAPS rechargeable transponders. The only acceptable transponder types are:

- Classic MX
- Flex MX
- X2 MX



Figure B- 68: List of approved and unapproved transponders

Subscriptions for Flex MX, X2 MX, or TR2 MX transponders must be up-to-date and all Flex MX, X2 MX, and TR2 MX transponders must have been activated before Transponder Check at Technical Inspection.

Visit <http://www.mylaps.com> for more information.

Allowed Transponders					
Transponder Name	MX Classic	MX Flex	X2 MX Rechargeable	X2 MX Direct Power	TR2 MX
Picture					
Price Model	One Time Purchase	1, 2 or 5 Year Subscription	1, 2 or 5 Year Subscription	1, 2 or 5 Year Subscription	1, 2 or 5 Year Subscription
Sales Availability	No Longer Available	No Longer Available	Currently Available	Currently Available	Currently Available
Renewal Availability	-- NA --	1, 2 or 5 Year	1, 2 or 5 Year	1, 2 or 5 Year	1, 2 or 5 Year
MyLaps' End of Support	1-6-2017	1-6-2017	Ongoing	Ongoing	Ongoing
MyLaps' End of Service	1-6-2019	1-6-2019	Ongoing	Ongoing	Ongoing
Insurance Included	No	Yes, With Subscription	Yes, With Subscription	Yes, With Subscription	Yes, With Subscription
Warranty Included	3-year Limited Warranty	Unlimited warranty	Unlimited warranty	Unlimited warranty	Unlimited warranty
Mounting Type	Classic Quick Release Clip	Classic Quick Release Clip	X2 Quick Release Clip	Direct Mount + Cable Harness	TR2 Holder
Power Source / Time on Battery	Rechargeable / 4 Days	Rechargeable / 5 Days	Rechargeable / 5 Days	Direct Power (12V) With Built in Battery Backup	Rechargeable / 5Days
Time Needed to Charge	16 Hours	16 Hours	4 Hours	-- NA --	5 Hours
Charger Type	Black 12V Cradle	White 5V USB Cradle	5V USB X2 RaceKey	-- NA --	5V TR2 Charge Cradle

Figure B- 69: Chart of transponder information

B.13.2.2 Purchase

All teams are responsible for purchasing their transponder(s) directly through MyLaps.

<http://www.mylaps.com>

B.13.2.3 Mounting

All vehicle transponders shall be mounted in the proper location, correctly oriented, and using sufficient fastening methods.

B.13.2.3.1 Orientation

The transponder shall be installed vertically to the frame in the orientation shown in figure B-70. The transponder shall also be oriented so the transponder number can read “right-side up.”



B.13.2.3.2 Location

The transponders should be mandatorily mounted on the right side of the vehicle, forward of the seat, and preferably within the lower horizontal plane of the front suspension. The transponders shall be no more than 61 cm (24 in) above ground level.

The transponders shall have an open, unobstructed path between the antenna on the bottom of the transponders and the ground.

i *Metal and carbon fiber may interrupt the transponder signal.*

✓ **The transponder signal will normally transmit through fiberglass and plastic.**

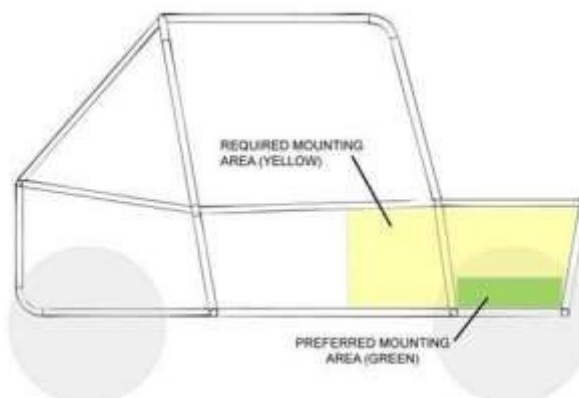

Figure B- 70: Transponder Mounting Location

B.13.2.3.3 Fastening

Each transponder is supplied with a mounting bracket. Teams are advised to weld a small plate to their frame to attach the transponder mounting bracket.

 **Attaching the bracket with an M4 pan OR flat head bolts with lock nuts OR wire is strongly suggested.**

B.13.2.3.4 Interference

RF systems transmitting voice and/or data can cause harmful interference with the signal transmitted by the transponder. Care should be taken when designing, fabricating, or maintaining RF systems near the transponder.

 **The transponder equipment operates at a frequency of 3.59 MHz**

B.13.3 Vehicle Numbers

Vehicle numbers are used by the organizers and officials to positively identify team vehicles. Teams must design numbers to be visible in all race conditions or keep them clean and conspicuous. Numbers shall not be obscured by any other portion of the vehicle.

 *Numbers that are not easily read may be black flagged and might not be scored during the endurance event.*

B.13.3.1 Required Numbers

Two/Three primary numbers are required to be securely affixed to the car. The vehicle's number shall be readily visible from the left side, right side, and the front of the vehicle and strongly contrast with the number's background color. The use of adhesive to stick the numbers to the body panels is prohibited.

B.13.3.2 Required Font

Vehicle numbers shall be displayed in either the "Highway Gothic Regular" font or "Century Gothic Bold" font. No other fonts are permitted. Examples of both fonts are given below.

Highway Gothic: 1 2 3 4 5 6 7 8 9 0

Century Gothic Bold: 1 2 3 4 5 6 7 8 9 0

Figure B- 71: Approved vehicle number font examples

B.13.3.3 Location

B.13.3.3.1 Side Numbers

Side numbers mounted to the left and the right sides of the vehicle shall be mounted above the SIM and aft of the plane of the RRH. Side numbers shall not be visually obstructed by any part of the vehicle.

B.13.3.3.2 Front Number

The angle of the plane of the front-facing numbers, when affixed to the vehicle above the SIM, shall be less than or equal to 45 deg. from vertical.

The angle of the plane of the front numbers, when affixed to the vehicle below the SIM, shall be less than or equal to 15 deg. from vertical.

B.13.3.4 Orientation

Numerals shall be aligned along a common horizontal line, and the entire number of panels shall be mounted in a generally horizontal orientation (+/- 3.0 degree tolerance) to facilitate fast vehicle identification. The number panels shall have 25.4mm (1.0 in.) spacing between numerals.

B.13.3.5 Number Size

The primary cut-out numbers must be at least 152 mm (6.0 in) high, dimension “H” in Figure B-73. The primary cut-out numbers shall have a stroke width in proper proportion to the font design for the given character height. The primary cut-out numbers shall be mounted such that the projecting face is a minimum of 13 mm (0.5 in) from the background panel.

 **Avoid sharp edges or points on the inner and outer edges of the cut-out numbers.**

B.13.3.6 Backing Panel

Each number on the vehicle shall have a highly contrasting background to facilitate easy reading. The edges of the backing panel shall be no less than 25.4 mm (1.0 in.) from the edge of the numbers (dimension “D” in Figure B-73). Numbers may be outlined to provide enhanced contrast. Number backing panels must be securely fastened to the vehicle frame.



Figure B- 72: Vehicle Numbers, Example

B.13.3.7 Number Color

Teams are free to select their number and backing panel colors, provided that the colors are high contrast and facilitate fast vehicle identification. The number backing panel shall be all one color and all numerals shall be of matching color. See Figure B-73.

B.13.4 SAEINDIA Logo

Two (2) SAEINDIA logos must be displayed on the vehicle in prominent locations. These will be distributed during the registration at the competition.

B.13.5 Sponsor Identification

Teams may display advertising from their vehicle's sponsors, provided it is in good taste and does not conflict with the vehicle's number. SAE International may require all entrants to display advertising from the competition sponsors.

- Teams must keep sufficient space (approximately 10 X 10 inches) unoccupied on the firewall, on the left side of the driver (refer to the yellow highlighted region in Figure B-73). This region will be used for putting stickers as part of the Technical Evaluation (three stickers) and weighment (one sticker) process.



Figure B- 73: Portion for Technical Evaluation and Weighment Stickers (Highlighted in Yellow)

ARTICLE B.14: ERGONOMIC REQUIREMENTS FOR DRIVER SAFETY

B.14.1 Roll cage Requirements

- Teams are advised to design the Driver's cockpit giving maximum safety to the driver. Reducing weight/compact roll cage can be a secondary part of it.
- Brackets/Mountings welded in the roll cage to be filleted to avoid sharp edges which may prompt injury to team member/Driver.
- Ensure Good visibility for the driver through FBM.
- Triangulate in areas that require more strength.

B.14.2 Sub-System Requirements

B.14.2.1 Steering Wheel Clearances

There must be a minimum clearance (RA) of 220mm between the driver's chest or upper body/torso, whichever is closest to the steering wheel, as illustrated in Figure B-75.

 Teams must ensure that their vehicle meets B14.2.2. Teams that do not meet this criterion will be marked as 'not cleared safety scrutiny'.



Figure B- 74: Driver's Chest Clearance

B.14.3 Driver Knee Safety Requirements

This requirement deals with the safety requirements to be followed to ensure the driver's knees are not coming out of the roll cage. The maximum height of the knees that can be allowed above the SIM member when viewed from the side is 76mm (3in) as shown in Figure B-74. The check will be done when the driver's foot is kept on the pedals, hands on the steering wheel, and with the comfortable pedal operating position.

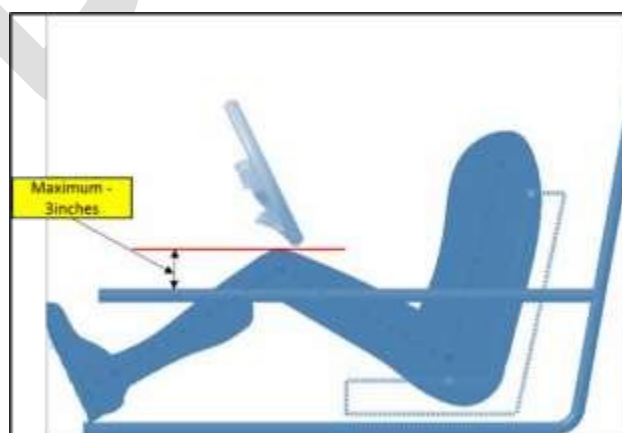
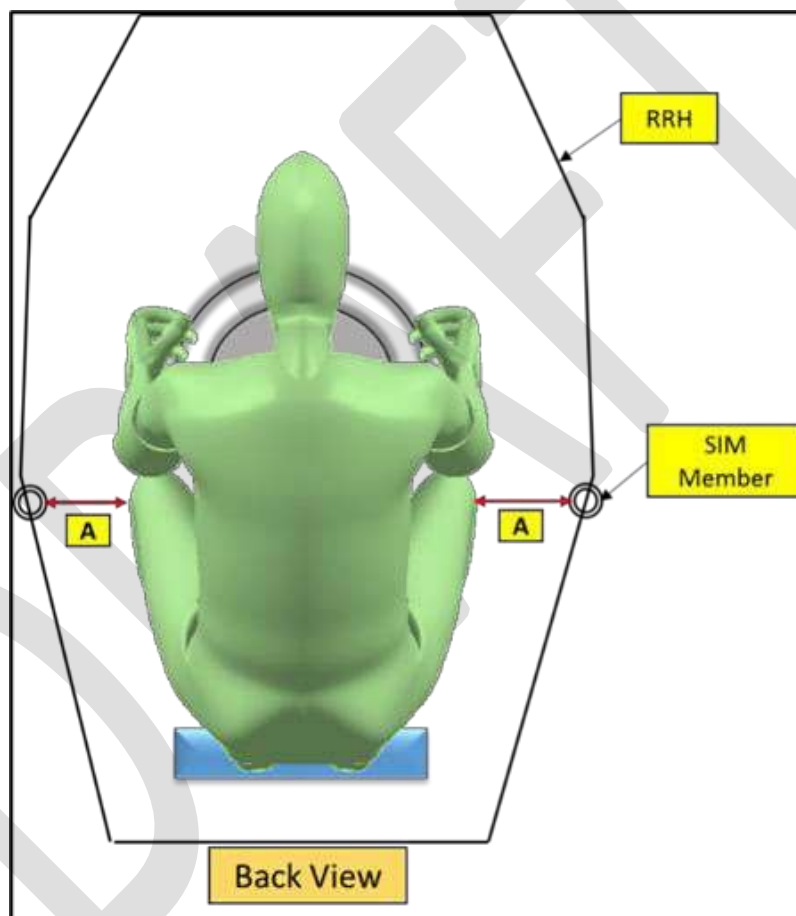

Figure B- 75: Driver Knee Safety Requirement

In line with the above rule, teams are required to meet the lateral clearance requirement of the knees. This is also measured when the driver’s feet are on the pedals and hands on the steering wheel. The dimension “A” mentioned in figure B-76 should be a minimum of 76mm (3in) w.r.t SIM member inner surface.

Teams must ensure that their vehicle meets both the clearances mentioned under B14.3(as per Figure B-75 and Figure B-76), both the limits should be met simultaneously. Teams that do not meet these criteria will be marked as ‘not cleared at safety scrutiny’.

Figure B- 76: Driver Knee Safety Lateral Clearance



PART C: Preliminary Round - 40 Points + 10 Points

Preliminary Round of will be the first round of the event hBAJA SAEINDIA event. The scores obtained in this round will be added to the total score obtained by the team in all the respective phases of the hBAJA SAEINDIA event.

- The objectives of the Preliminary Round are as follows:
 - To acquaint the teams with the objectives of the hBAJA SAEINDIA Event.
 - The teams should have fundamental knowledge of Automotive Engineering like Chassis, Body, Suspension, Steering, Brakes, Engine, Transmission, CVT, Driveline, Electricals, Electronics, Hardware Integration, Software Architecture Design, Sensors, etc. and Design Criteria, Manufacturing Criteria, Materials, Calculations, CAD/CAE Analysis, Engine Simulation, Vehicle Dynamics, Ergonomics, DFMEA/PFMEA, Performance Testing, Validation & Certification for the above components/ systems and vehicle as a whole.
 - The teams are required to familiarize themselves with the technical guidelines and limits for the design of the hBAJA Vehicle as per the latest *hBAJA SAEINDIA rulebook as applicable*.
 - To make various concepts and lay down complete technical specifications of the proposed vehicle along with a CAD model, CAE Analysis, selection of sub systems and execution of team plans.
 - To understand Make or Buy Decisions based on facilities & confidence available and perform estimated Cost Analysis, Weight Analysis, Team building, MS Project Planning, etc.
- Entire evaluation process will be conducted digitally on a Video Conferencing Portal. Standard Operating Procedure (SOP) of the Video Conferencing Software will be released separately.
- Maximum 5 team members per team which must include either Captain or Vice-Captain will be allowed for this round.
- One Faculty member, in addition to the team members, will be allowed only as a silent observer.
- Teams must strictly adhere to their respective timelines.
- Teams must prepare for the following sub-events:
 1. **Presentation Round:** A maximum of 45 mins will be allotted per team to present their vehicle design which includes,
 - Presentation by the team to showcase their design: **25 mins**
 - Questions put up by the panel to be answered by the team: **20 mins**
- **Quiz Round:** The Quiz will consist of questions from General Engineering/ Automotive Engineering and BAJA SAEINDIA 2026 Rulebook

Further details regarding the Preliminary Round shall be released on [BAJA SAEINDIA® Forum](#)

PART D: STATIC EVENTS – 325 POINTS

ARTICLE D.1: SCORING

Event	Description	Points
Physical Static Events	Sustainability Event	25
	Design Event	100
	Cost Event	50
	Sales Event	50
	Manufacturing Excellence	50
#Bonus regarding Static Event finals	Innovation Event	NA
	CAE Event	NA

 Any change in scoring pattern shall be informed to the teams through [BAJA SAEINDIA Forum](#).

ARTICLE D.2: ENGINEERING DESIGN EVENT - 100 Points

D.2.1 Engineering Design Event Overview and Objective

The objective of the engineering design event is to evaluate the engineering effort that went into the design of the vehicle, how the engineering meets the intent of the market, and simulate real-world engineering design projects and their related challenges.

The vehicle that illustrates the best use of engineering to meet the design goals and the best understanding of the design by the team members will win the design event.

D.2.2 Format for Document Submission

Sr	Document	Submission	File Type
1	Design Report	Compulsory	.pdf
2	Design Specification Sheet	Compulsory	.xlsx
3	Design Comparison Sheet	Only for Returning Teams	.pdf
4	DVP&R and DFMEA	Compulsory	.xlsx

The actual format and process of the Engineering Design Event may change from year to year as determined by the organizing body. The engineering design event guidelines shall be released on [BAJA SAEINDIA Forum](#). Previous event guidelines are available on the [BAJA SAEINDIA Website](#).

D 2.3 Judging Process

Students will be judged on the creation of design specifications and the ability to meet those specifications, computer-aided drawing, analysis, testing and development, manufacturability, serviceability, system integration, and how the vehicle works together as a whole. Each of these parts of the engineering product development cycle will be judged within the following subsystems: Vehicle Overview and Integration, Roll cage & Ergonomics,

D.4.2 Format for Document Submission

Sr	Document	File Type
1	Sales Report	.pdf

The actual format and process of the Sales Event may change from year to year as determined by the organizing body. The sales event guidelines shall be released on [BAJA SAEINDIA Forum](#). Previous event guidelines are available on the [BAJA SAEINDIA Website](#).

D.4.3 Judging Process

The presentation event will be scored based on the following five categories:

- Establishing the current scenario of the company and current status.
- Understanding the market and customer requirement, positioning the product accordingly.
- Showcasing company financials, the current assets, liabilities, revenue, profit & losses, RoI, RoCE
- Establishing core USPs of the product using various tools including market research, SWOT, PESTEL etc.
- Marketing strategy to promote the product.
- Project timelines, execution strategies, readiness for worst case scenarios etc.

The team that makes the best presentation will receive the highest score regardless of the finished quality of their actual vehicle.

ARTICLE D.5: SUSTAINABILITY EVENT - 25 POINTS

The mobility industry is actively navigating the complexities of transitioning towards propulsion systems powered by renewable energy sources. However, the concept of sustainability extends far beyond the adoption of alternative fuels. Engineers must possess a comprehensive understanding of the entire lifecycle of their designs to make conscientious design decisions by considering the environmental impact of the materials they choose. There is a growing demand for sustainable design practices, which has prompted BAJA SAEINDIA to incorporate the fundamental principles of sustainable engineering into the Sustainability Event.

For mBAJA & hBAJA -

The objective is to encourage teams to reduce the exhaust emission using different technologies and use sustainable design principles into their vehicle design. Teams will be evaluated based on Virtual Evaluation, Prototype Evaluation & Emission test conducted at the event site.

For eBAJA -

The objective is to encourage teams to build efficient vehicles using sustainable design principles. The same will be evaluated through a combination of Virtual Evaluation as well as battery capability to provide a maximum vehicle range with minimum discharge.

The actual format and process of the sustainability event may change from year to year as determined by the organizing body. The sustainability event guidelines shall be released on [BAJA SAEINDIA Forum](#).

The various sub-rounds of Sustainability Event will be spanned across multiple phases of BAJA SAEINDIA event. The winner of Sustainability Event for a given format will be based on overall performance across all the sub-rounds.

ARTICLE D.6: ENGINE SIMULATION

- The objective of this event is to evaluate Students' understanding of use of tools used to maximize the use of Engine Available power for hCNG Application.
- BAJA SAEINDIA Committee will suggest a suitable tool to the students to show the same, details of which will be shared in due course of time.
- Please refer [BAJA SAEINDIA Forum](#) and [BAJA SAEINDIA Website](#) regularly for details.

ADDITIONAL EVENT : MANUFACTURING EXCELLENCE EVENT – 50 POINTS

Manufacturing Excellence event is aimed in bring out students' capabilities to use best industry manufacturing practices during the Overall Buggy Development Process. By focusing on reducing waste, optimizing resource utilization, enhancing process reliability, and empowering employees, teams' can deliver consistent value and stay competitive in the Event.

As a result BAJA SAEINDIA from 2026 has decided to gauge the same through a part of a Event. The actual format, process, and judging criteria of the Manufacturing Excellence Event may change from year to year as determined by the organising body. The Manufacturing Excellence Event guidelines shall be released on the [BAJA SAEINDIA Forum](#). Previous event guidelines are available on the [BAJA SAEINDIA Website](#)

ARTICLE D.7: INNOVATION EVENT – NA POINTS

D.7.1 Innovation Event Overview and Objective

The Innovation Event is conducted in BAJA SAEINDIA with the sole purpose to drive students towards new developments, idea generation and incubate positive problem-solving attitude by harnessing their engineering abilities. BAJA SAEINDIA consistently encourages teams to push the boundaries of innovation, not only in vehicle design but also in refining manufacturing processes and implementing cost-effective techniques.

The primary objective of this event is to challenge teams to brainstorm and devise innovative solutions and apply them to real-world problems. The solution must be presented as a tangible Proof of Concept at the main event site.

D.7.2 Format for Document Submission

Sr	Document	File Type
1	Abstract	.pdf

The actual format and process of the Innovation Event may change from year to year as determined by the organizing body. The innovation event guidelines shall be released on [BAJA SAEINDIA Forum](#). Previous event guidelines are available on the [BAJA SAEINDIA Website](#).

D.7.3 Judging Process

The abstract submitted by the teams will be evaluated based upon the following criteria -

1. **Comprehension of the Problem Statement** - The extent to which the team demonstrates a clear understanding of the stated problem.
2. **Simplicity and Usage Convenience of the Proposed Solution** -The simplicity and ease of use of the proposed solution, ensuring it is user-friendly and straightforward.
3. **Innovative Advantages** - Evaluation of the proposal's advantages concerning existing or similar products in the market, emphasizing innovation and distinctiveness.
4. **Potential Cost Reduction** - Assessment of the proposal's potential to reduce production costs, thereby enhancing cost-efficiency in implementation.

D.7.4 Innovation Finals – NA POINTS

D.7.4.1 Overview

Innovation Finals are held at Phase 3 event site and the teams will be shortlisted on the basis of the abstract submitted during Phase 2. The number of finalists may vary and is determined by the number of entries and the results of the Innovation Event conducted during Phase 2.

D.7.4.2 Presentation Format

The Innovation Efficient Finals format, timing, and instructions will be released on the [BAJA SAEINDIA Forum](#).

E.2.4 Technical Safety Scrutiny

Each vehicle will be inspected to determine if it complies with the requirements and restrictions of the BAJA SAEINDIA® rules. This inspection will include an examination of the driver's equipment including helmet and arm restraints, a test of driver exit time and to ensure that all drivers meet the requirements of the rules. Each team must bring the following items to inspection.

- A. Frame Material Documentation: Receipts documenting the materials purchased, or otherwise acquired, and used to build the frame. Note that material certificate from the supplier as well as certificate of MATERIAL COMPOSITION and MECHANICAL PROPERTIES CONFIRMATORY TEST AT AUTHORIZED LABORATORY ARE MANDATORY. Roll cage tube material suppliers' test reports and Local Test Reports need to be submitted.
- B. Roll Cage Specification Sheet: A completed copy of the Roll Cage Specification Sheet. In case of a higher grade of Steel is used then the supportive calculations should prove that cross-section is adequate and bending stiffness and strength are achieved.
- C. Technical Inspection check sheet: At the college level, **Self-Technical Inspection check sheet** compliance is expected and the same should be submitted while technical evaluation is being done.
- D. Drivers Present: Both drivers must be present at technical inspection with a valid license and complete safety gear.

The safety scrutiny will also check for electrical systems, kill switch, lighting, reverse lamp, Buzzer (if installed), horn, wiring, and their mountings, etc. Both the external and cockpit kill switches will be tested for functionality. The system should pass the test.

All hardware fasteners and their mountings should comply with basic requirements.

- Any major rework suggested during the technical inspection must be carried on in respective vehicle pits and not in any other place (Refer to Part H: Miscellaneous Topics – Article 1).**

E.2.5 Dynamic/panic brake test

The objective of this test is to ensure the vehicle is safe for driving, while it goes up to the speed of 60 kmph. The test requires the vehicle to attain a minimum speed of 40 kmph within 200 ft. distance and should be capable of stopping with all four wheels locked (within the distance of 26 ft or 8 m).

- All four tyres must be marked with a radial strip of 25 mm (1.0 in) width using white paint (on the outer side of tyres) for wheel lock check. The markings should be done by the teams. Refer to the region highlighted within the red box in Figure C-1.**



Figure C- 1: Tyre Markings for Wheel Lock Check

Every team should demonstrate that all four-wheel brakes are effective for high-speed braking. Each vehicle must come to rest in an approximately straight line specified by the inspectors. If a vehicle fails to pass any part of the inspection, it must be corrected/modified and brought into compliance with the rules before it is permitted to operate.

Only two attempts are permitted for the Brake test.

On successful completion of brake test, the vehicle is considered for 'Technical Evaluation OK' and 3rd sticker is pasted on the vehicle. Log Sheet to be submitted to brakes, technical evaluator.

- ❑ **FOR IN-BOARD BRAKES:** Since teams are using inboard brakes which are mounted on the shaft, the other side of the shaft is connected with UJ, or the CV joint creates play while the brake is in action. This results in a delay in brakes being applied on one of the rear wheels and further rotation in it.
- ❑ In such a case only half turn rotation (max 180 degrees) will be considered. Brake effectiveness will be allowed only if the rotation of all 4 wheels stops, and the vehicle comes to stop at a place instantly.
- ❑ Juddering of wheels due to reactive forces on rotor and brake caliper will be considered ineffective braking. Generally, two-wheeler brake systems show this characteristic. Therefore, it is not recommended to use on BAJA SAEINDIA® vehicles.

E.3 Inspection Stickers

- 1 A multi-part inspection sticker will be issued in sections to each vehicle as each of the three parts of the technical evaluation is completed. The inspectors will place the inspection sticker on the right side of the firewall above the driver's shoulder. The inspection sticker must remain on the vehicle throughout the competition. Vehicles without all parts of the inspection sticker must not be operated under power.
- 2 Any or all parts of the inspection sticker may be removed from any vehicle that has been damaged or which is reasonably believed to not comply with the rules.

PART F: VALIDATION EVENT- 75 POINTS

ARTICLE F.1:OVERVIEW

The Virtual Dynamic Events commenced in 2021, due to the prevalent COVID-19 pandemic, which proved to be a huge success for BAJA SAEINDIA, and the participating teams. Thus, BAJA SAEINDIA® has decided to continue Virtual Dynamic Events as an addition to the Physical Dynamic Event. Under the partnership with a virtual automotive testing software provider (to be finalized at a later stage of the event) for the 2025 season, BAJA SAEINDIA will provide a **fixed number of software licenses to all the registered teams**. Extensive training will also be provided to the teams to help model their vehicle, build off-road terrains, and simulate the vehicle in race conditions on the software. This value addition of vehicle optimization using a virtual automotive testing solution shall aid the teams to design and build a vehicle at par with professional racing teams.

ARTICLE F.2:OBJECTIVE

The goal of the Virtual Dynamic Event is to develop a single-seat, all-terrain vehicle designed by the team in a virtual environment and maximize the virtual vehicle's performance in race-oriented scenarios.

ARTICLE F.3:EVENT CONDUCT

The Virtual Dynamic Events will be live-streamed; hence the teams will get a unique opportunity to witness and enjoy the event holistically.

All teams must strictly note that the value of the parameters, to be defined in the Vehicle Model that shall be designed in the software, must comply with the set of rules defined in the latest version of BAJA SAEINDIA® Rulebook for the calendar year.

The virtual vehicle parameterization must be identical to the values in the Design Spec Sheet submitted by the team. All the values to be defined by the teams must have proper justification concerning the team's vehicle design, which might be asked to be produced for review by BAJA SAEINDIA® judges at any point of time during the event. Any teams found deviating from the Design Spec Sheet and/or insufficient in justifying the specified values for their vehicle shall be penalized.

 **Teams are required to visit the [BAJA SAEINDIA Forum](#) for the rules and updates about the set of guidelines for Virtual Dynamic Events**

PART G: DYNAMIC EVENTS – 675 POINTS

The dynamic events are intended to determine how the BAJA SAEINDIA® vehicles perform under a variety of conditions. Note that the organizers may modify the dynamic events to address local conditions, weather, or resources.

ARTICLE G.1: SCORING SUMMARY

DESCRIPTION	POINTS
Acceleration	50
Efficiency	100
Maneuverability	75
Endurance Performance	400
Validation Event	50
Total Dynamic Events	675

Figure E- 1: Dynamic Events, Table of Points

 Any change in scoring pattern shall be informed to the teams through [BAJA SAEINDIA Forum](#).

ARTICLE G.2: PRACTICE

G.2.1 Objective

Organizers may or may not provide a practice track to teams. A practice track allows teams to test or tune their vehicle within the limits of the rules.

G.2.2 Course

If the organizer provides a practice track, the course length and features are at the organizer’s discretion.

G.2.3 Procedure

After a safety check, vehicles are signaled to enter the practice track. After a predetermined time set by the track worker, the vehicle is signaled to exit the practice track.

G.2.4 Penalties

Teams may be signaled to exit the practice track or barred from using the practice track if the track worker or competition officials observe unsafe conditions or behaviors.

G.2.5 Signals and Signage

See F.8.9 - Signals and Signage.

G.2.6 Scoring

There is no score awarded for practice.

ARTICLE G.3: ACCELERATION

G.3.1 Objective

The Acceleration Event is designed to measure each vehicle’s ability to come up to speed quickly from a standing start.

G.3.2 Course

Acceleration is measured as the time to complete a 30.48 m (100 ft.) or 45.72 m (150 ft.) flat, straight course from a standing start. The course surface may vary from pavement to loosen dirt. The choice of course length and surface are at the organizer’s discretion.

G.3.3 Procedure

After a safety check, vehicles are positioned at the start line of the course. The track worker will check that the driver is ready to begin. Once the driver is ready, the track worker will signal the driver to proceed down the course. After completing the run on the course, the vehicle will be directed to the course exit.

Each vehicle may make two (2) runs on the course.

G.3.4 Penalties

- Stall At Start – Run DQ
- False Start – Run DQ
- Driving off Course – Run DQ

The organizer may modify the penalties imposed for different violations to account for differences in the length or design of specific event courses.

G.3.5 Signals and Signage

See F.8.9 - Signals and Signage.

G.3.6 Scoring

The maximum number of available points for the acceleration event is 50 points.

Scoring will be based on the better of the two attempts. Timing will be performed with an electronic timing system.

The following equation will be used for the acceleration score (S_{ac}):

$$S_{ac} = 50 \times \frac{t_{max} - t_{run}}{t_{max} - t_{min}}$$

Where:

t_{min} is the lowest (fastest) time by any vehicle

t_{run} is the time recorded for a vehicle’s run to be scored.

t_{max} is the minimum of the following:

- The longest (slowest) time by any vehicle, or
- 1.5 times t_{min}

Vehicles with acceleration times that are more than 1.5 times that of the fastest vehicle will not receive a score for this event. Teams attempting the event but exceeding the time limit will be classified as “Excess Time.”

ARTICLE G.4: MANEUVERABILITY

G.4.1 Objective

Maneuverability is designed to assess each vehicle’s agility and handling ability over off-road terrain. Teams will attempt to maneuver through the course with a minimum time.

G.4.2 Course

The course may consist of a variety of challenges at the organizer’s option, possibly including tight turns, pylon

maneuvers, ruts, bumps, drop-offs, sand, rocks, gullies, logs, and inclines.

G.4.3 Procedure

After a safety check, vehicles are positioned at the start line of the course. The track worker will check that the driver is ready to begin. Once the driver is ready, the track worker will signal the driver to proceed down the course. After completing the run on the course, the vehicle will be directed to the course exit. Each vehicle may make two (2) attempts at the course.

G.4.4 Signals and Signage

See H.8.9 - Signals and signage.

G.4.5 Penalties

The organizer will select penalty types imposed for different violations to account for differences in the length or design of specific event courses. Penalties are time added to the total time a vehicle took to complete the course for a given run. The organizer will announce penalties on their event website or at a mandatory team meeting.

Example Penalties:

Pylon or Obstacle Moved -	2 seconds
Missed Gate* -	10 seconds
Excessive Driving Off Course** -	Run DNF
False Start -	First- Rerun at the end of the line Second- Run DNS

**Note 1: Missed gate is when 2 or more wheels are outside the course.*

***Note 2: Excessive driving off course is when any one wheel of the vehicle is outside the boundary line of the course over a considerable distance. The distance is discretionary and will be determined by the course captain.*

G.4.6 Scoring

The maximum number of available points for the maneuverability event is 50 points.

Scoring will be based on the best of the two attempts. Only vehicles that complete the maneuverability course within a time not exceeding 2.5 times that of the fastest vehicle will receive a score. If a vehicle is on the course for a time that exceeds 2.5 times the fastest time recorded to that point, then the attempt may be declared over, and the vehicle may be removed from the course and scored as "Excess Time."

Maneuverability scoring is based on the vehicle's time to complete the course. Penalties are added to the vehicle's time for a given run.

The following equation will be used for the maneuverability score (S_{man}):

$$S_{man} = 75 \times \frac{t_{max} - t_{run}}{t_{max} - t_{min}}$$

Where:

t_{min} is the lowest (fastest) time by any vehicle.

t_{run} is the time recorded for a vehicle's run to be scored. t_{max} is the minimum of the following:

- The longest (slowest) time by any vehicle, or
- times t_{min}

ARTICLE G.5: EFFICIENCY EVENT

The Efficiency event evaluates the fuel/energy used to complete a given lap or course.

Teams will be gauged on the amount of pressure drop registered for a given length of track.

The details of the same will be released on BAJA SAEINDIA Forum & Website.

ARTICLE G.5.1: VALIDATION EVENT

BAJA SAEINDIA® introduced the Validation Event in 2022 for student teams to wield simulation tools and fortify vehicle design, by gauging the results of the virtual vehicle run in tandem with the physical vehicle run.

The objective of the Validation Event is to authenticate a system-level coherence of the Virtual Vehicle with the Physical Vehicle built by the teams participating in Phase 3 of the BAJA SAEINDIA® event.

The Validation Event guidelines will be released on [BAJA SAEINDIA Forum](#).

ARTICLE G.6: ENDURANCE PERFORMANCE

G.6.1 Objective

The endurance event assesses each vehicle's ability to operate continuously and at speed over rough terrain with obstacles in potentially adverse weather conditions (rain, snow, etc.). The endurance event may be run for time or distance. The default is one (1) hour and the vehicle with the most laps (orbits) around the course is declared the winner.

G.6.1 Course

The endurance course is a closed loop measuring approximately 1.0 km to 4.0 km. The endurance course may feature different surfaces (e.g., dirt, grass, sand, mud, gravel, stone, and asphalt). The endurance course will feature various obstacles and terrain to test the vehicle's durability, traction, and speed.

G.6.2 Procedure

G.6.2.1 Pre-Gridding

Teams will pre-grid before the endurance event and be placed into starting position based on each team's performance in a previous dynamic event, or set of dynamic events, to be determined by the organizer. Pre-gridding will close at a pre-determined time by the organizer. Teams late to pre-grid will be gathered in the pit exit lane and released to the track after the race has started.

G.6.2.2 Compliance Check

During pre-gridding, or after pre-gridding closes, for mBAJA vehicles engines will be started and eBAJA vehicles should be kept in "Ready to Drive" mode, and the Technical Inspector will perform a compliance check. During compliance check and gridding, the driver and vehicle may only have one team member accompany them. The compliance check includes, but is not limited to inspection of the following:

- Helmet Certification
- Helmet Fitment and Securement
- Safety Harness
- Driver Equipment
- Driver Wrist Band
- Fire Extinguisher
- Kill Switches
- Brake System

Unprepared drivers or out-of-compliance vehicles deemed unsafe or not ready to drive will be ordered out of

the gridding line by Technical Inspectors and sent to the paddocks to make corrections. Vehicles not ready to drive must check in at the pit exit lane to be admitted to the track.

G.8.3.3 Gridding

Once the compliance check is complete, vehicles begin to form the grid and approach the start line as marshaled by track workers or Technical Inspectors.

G.6.3.4 Starting

The endurance event may be started by a funnel start, standing staggered start, or rolling start. A funnel start is when cars are arranged in a conical formation and released all at once. A standing staggered start is used to release cars in groups of two with a delay in between groups. A rolling start allows a run-in distance to the start line. The rolling start may be performed on the course. The start type will be determined by the organizer.

All vehicles will be considered to have begun the race simultaneously at the time when the starter releases the first vehicle onto the course regardless of their actual position in the grid.

G.6.3.5 Running

Endurance will be run as either:

- A single one (1) hour race
- A predetermined and published distance
- Elimination heats are followed by a final in which the total time of one elimination heat plus the final is 1 hour. The organizer will announce the structure of the event before the start.

Vehicles will safely navigate the course and accrued laps (orbits) to be counted and scored.

G.6.3.6 Driver Change

During the course of the endurance race, if a driver change is necessary, the vehicle can be taken to either the race pit or fueling station (for mBAJA vehicles) or Accumulator(s) Swapping area (for eBAJA vehicles), as per instructions. Here registered the second driver can take charge and continue further in an endurance event.

The organizer reserves the right to require at least one driver change during the endurance event.

G.6.3.7 Refueling

G.6.3.7.1 Location

The Fueling Zone (FZ) consists of the Fueling Area (FA), Fuel Quarantine Area (FQ), Crew Area (CA), and Harness Check Area (HC).

Only three (3) people from any given team, including drivers, are allowed within the Fueling Zone (FZ) at any one time.

Active refueling occurs in the FA. All stored fuel not in use is located in the FQ. Vehicles and drivers will proceed to the HC before returning to the track.

G.6.3.7.2 Procedure

Vehicles requiring fuel will exit the track at the designated location and proceed at walking speed to the fueling area.

Before refueling, the vehicle must be stopped, the engine shut off, and the driver **completely out of the vehicle**. The driver may not be tethered in any way, by a harness, communications equipment, or clothing.

Before refueling, a team's pit crew member must have a fire extinguisher ready and pointed at the fuel transfer point on the vehicle. The exiting driver is the only team member permitted to remove the fuel tank cap.

A team refueling their vehicle before the driver is clear of the vehicle or who fails to have a fire extinguisher

present and pointed at the fuel transfer point will be penalized.

The fueling area is to be clear of anyone not immediately servicing a car.

A fire extinguisher must be present and pointed at ANY transfer of fuel, including re-filling a smaller container from a larger one when a vehicle is not present.

G.6.3.7.3 Driving in the Fuel Area

All cars must operate at a walking speed while in the Fueling Area and when entering/exiting the area. Any team found speeding in the fueling area will be assessed a penalty.

Cars may not be pushed into the Fueling Area (FA) without a driver being present and prepared to drive (i.e., wearing all required safety equipment).

G.6.3.7.4 Fuel Containers

Teams are not permitted to bring fuel to the event.

Fuel will be provided by the organizers in a specially designated fuel bunk in an Indian event. Teams are not permitted to bring fuel to the event. Fueling will be done only in the designated FZ area. Any team found with fuel in the paddocks during the event will be disqualified from **participation in any event and points earned thus far will be eliminated.**

G.6.3.7.5 Repairs in Fueling Area

No work requiring a tool may be performed in the Fueling Area. Teams are allowed to make adjustments that do not require any tools. Examples include driver harness, seat position, spring-damper preload, etc.

Tools of any kind, backpacks, wagons, extra driver equipment, and coolers are specifically prohibited. Extra driver equipment may be brought to the Fueling Area for use, but extra driver equipment may not be stored in the Fueling Area.

G.6.3.8 Service

G.6.3.8.1 Remote Pit

The organizers may elect to create a remote pit for the endurance event. Any vehicle requiring minor repairs and adjustments can be attended to in a remote pit near the endurance track.

G.6.3.8.2 Paddocks

Teams whose vehicle requires service and repairs may exit the track at the designated location and proceed at walking speed to their paddock. No repairs are permitted on the course at any time.

G.6.3.9 Recovery

Vehicles disabled on the endurance course may be recovered by track workers, or by designated recovery crews. Track workers will attempt to assist disabled vehicles. It is the driver's responsibility to assist and cooperate with the course marshals in removing the vehicle. Drivers may not exit the vehicle to start the engine. Drivers must be seated and secured in the vehicle before track workers will attempt to restart the engine.

If track workers are unable to assist a disabled vehicle, a recovery crew may transport the disabled vehicle to the paddocks. Drivers being towed to the paddock are required to remain seated and secured in their vehicle with all safety equipment on.

Recovery crews are dispatched and operate on a "first come, first serve" basis. No priority will be given to any team over another.

G.6.3.10 Finish

The Endurance event is finished when the lead car crosses the finish line after the time limit or distance has

been reached. Vehicles remaining on the track will be allowed to finish their lap. Vehicles in the fuel zone or Accumulator(s) Swapping area will not be allowed back on the track after this time.

As vehicles cross the finish line, track workers will direct vehicles to the paddocks or the impound area (if required). All post-event traffic shall be at walking speed.

G.6.3.11 Impound

The organizers reserve the right to impound and inspect any vehicle during or after the endurance event. The Technical Inspectors will direct and instruct teams in impound on how to proceed.

hBAJA Teams may be required to surrender their engine, as per F.8.8 - Surrender of Engine.

G.6.3.12 Penalties

Event captains are the only personnel permitted to call and assess penalties during the endurance event. Event Captains are distributed throughout the endurance course during the event. Penalties during the endurance race will be signaled and vehicles ordered off the track from the black flag area. Event Captains may stop any vehicle, at any time, if they believe it no longer complies with the requirements and restrictions of the rules. All timed penalties are enforced from when the vehicle is in the black flag area, i.e., the time spent being towed back to the pits does not count towards the penalty.

G.6.3 Driver Equipment

Any driver that is not using all of the approved and required drivers' equipment will be flagged.

G.6.3.1 Mechanical Faults

All cars must remain in the as-approved condition in order to compete; any condition that is deemed to not meet this requirement will be flagged to make necessary repairs or adjustments. If a vehicle is stopped by officials for a mechanical fault, the fault must be corrected before it may re-enter the event.

G.6.3.2 Vehicle Assists

Certain areas of the endurance course have been identified as difficult obstacles. If a vehicle is assisted two times on the same obstacle, the vehicle may be black flagged, and the driver warned that one more assist will result in the removal of the vehicle for the remainder of the event.

G.6.3.3 Roll Over

If a vehicle rolls over (end over end, or over on its side) anywhere on the track two times (in any location, regardless of driver), the vehicle will be black flagged, and the driver warned that one more roll-over will result in removal of the vehicle for the remainder of the event. Rollovers will be judged at the discretion of the Event Captains. Any vehicle that rolls over must be inspected by the Technical Inspectors before returning to the track.

G.6.3.4 Endurance Penalty Table

Penalty Type	Infraction	1 st Offense	2 nd Offense	3 rd Offense
Fuel	Possession of fuel	DQ	-	-
Fuel	Fueling on the track	DQ	-	-
Fuel.	Use of tools on the car in the fuel area	Warning	10 minutes	DQ
Fuel	More than 3 people in the fuel area	Warning	10 minutes	DQ
Fuel	Fueling with the driver in the car	30 minutes	DQ	

Fuel	Fire extinguisher not ready during fueling	10 minutes	20 minutes	DQ
Fuel	Run out of fuel on the track	5 minutes	5 minutes	5 minutes
Driving	Vehicle Roll Over	-	Warning	DQ
Driving	Passing during a yellow flag	Warning	Discretionary	Discretionary
Driving	Failure to stop for the black flag when signaled	10 minutes	Discretionary	Discretionary
Driving	Leaving the course and advancing	5 minutes	Discretionary	Discretionary
Driving	Aggressive driving	10 minutes	DQ	-
Driving	Speeding in the pit or paddocks	5 minutes	20 minutes	DQ
Driving	Team member on the track	50 points/member/sighting		

Figure E- 2: Endurance Event, Table of Penalties

G.6.4 Signals and Signage

See H.9.9 - Signals and Signage

G.6.5 Scoring

G.6.5.1 Points

The maximum possible points for endurance are 300 points.

G.6.5.2 Determination of Winner

1. The team that completes the distance of the competition first or the greatest number of scored laps in the time set for the competition will be declared the winner.
2. In competitions of a given distance, the chequered flag will be given first to the leading car, then to the other finishers as they cross the finish line.
3. In competitions of a timed length, the chequered flag will be given first to the leading car as it crosses the finish line at or after the expiration of the specified duration, then to the other finishers in the order they cross the finish line.
4. If the leading car is not running at the expiration of the time limit, the chequered flag will be given to the next highest running car in the same manner.

G.6.5.3 Scored Laps

Scored laps are the number of full laps actually completed during the endurance event. Only full laps count, partial laps do not count for score. A vehicle must cross the timing line under its own power for a lap to be counted.

G.6.5.4 Finish Order

Finish order is the sequence in which vehicles cross the finish line after the lap scoring period has ended. Finish order determines the ranking of teams completing the same number of laps. For example, if the top four teams finish with the same number of laps, then they will be ranked 1st to 4th based on their finish order.

G.6.5.5 Bonus Points

Bonus points are additional points awarded to the first ten (10) vehicles on the leading (winning) lap, as

separated by finish order as required, in part to differentiate teams finishing with the same number of scored laps. Up to 10 bonus points will be awarded in the inverse order of finish. Thus, the first vehicle to cross the finish line in the highest lap group will receive bonus points equal to the number of cars on the lead lap (max of 10); the second vehicle will receive one less bonus point, etc. Example:

Position	Lap	Bonus Points
1	48	4
2	48	3
3	48	2
4	48	1
5	47	0

Figure E- 3: Endurance Event, Table of Bonus Points

G.6.5.6 Score

Endurance scoring is based on the number of laps the vehicle completes in the allowed time:

$$S_{en} = \left(350 \right) \times \frac{l_{team} - l_{min}}{l_{max} - l_{min}} + P_{bonus}$$

Where:

L_{max} is the maximum number of laps completed by any vehicle.

L_{team} is the number of laps completed by the vehicle to be scored. L_{min} is the minimum number of laps completed by any vehicle.

P_{bonus} is the number of bonus points awarded to a qualifying vehicle.

G.6.5.7 Heat Plus Final Scoring

When endurance is run as heats plus a final, the points for the event will be distributed between the heats and the final in proportion to the time/distance of each stage.

Thus, if endurance is run as one (15) min eliminations plus a (45) min final, the three hundred (300) total points will be allocated as seventy-five (75) points to each elimination heat plus two hundred twenty-five (225) points to the final.

ARTICLE G.7: GENERAL EVENT PROCEDURES AND REGULATIONS

G.7.1 Safety

G.7.1.1 Safety Vision

Safety is the primary consideration in the design of BAJA SAEINDIA® vehicles and the conduct of the competitions. No event or competition is so important that teams and organizers cannot take the time to work safely. All participants will strive to create a safe competition where all participants return home in the same condition in which they arrived.

G.7.1.2 First Aid / CPR / AED

While medical services are always on-site at BAJA SAEINDIA® events, teams are encouraged to be familiar with or trained in first aid, CPR, and the use of AED machines.

G.7.1.3 Approaching Others

All participants are empowered to directly and respectfully approach others if they see a hazardous or unsafe condition and notify the person in danger. Persons approached regarding a safety concern are obligated to respectfully acknowledge the situation and are encouraged to thank those who approached them for their concern.

G.7.1.4 Responsibility

At all performance events, it is the responsibility of the team to ensure both the vehicle and driver meet and follows all the requirements and restrictions of the rules.

G.7.1.5 Personal Protective Equipment

Teams are required to furnish and use their PPE, appropriate for the task being performed. This includes, but is not limited to:

- Safety Glasses
- Gloves
- Closed Toe Shoes
- Arc Flash Protection
- Hearing Protection

G.7.1.6 Key Hazards

All participants are encouraged to pay careful attention to the following situations:

G.7.1.6.1 Ascending and Descending

Maintain 3-point contact when ascending and descending stairs, ladders, steps, or tailgates. Watch for obstructions at the beginning and end of travel.

G.7.1.6.2 Pinch Points

Stay clear of pinch points from rotating machinery, doors, and other equipment.

G.7.1.6.3 Hazardous Release of Energy

Stay clear of sparks, chips, swarf, or other high-energy material. Check circuits for live wires before working on them. Depressurize high-pressure air, oil, or water systems before working on them. Take care when working around presses, rams, or other hydraulic equipment. Use care when jacking or lifting vehicles or other objects.

G.7.1.6.4 Vehicle Operations

Do not drive when distracted. Utilize a spotter when backing a vehicle.

G.7.1.6.5 Walking / Path of Travel

Take care to keep all walking paths clear of slip, trip, and fall hazards.

G.7.2 Rules of Conduct

G.7.2.1 Sportsmanlike Conduct

All BAJA SAEINDIA® participants can be proud of the excellent sportsmanship and cooperation among teams which are two of the hallmarks of the series. Good conduct and compliance with the rules and the official instructions are expectations and requirements for every team member.

Unsportsmanlike conduct can include arguments with officials, disobedience of official instructions, and the use of abusive or threatening language to any official or another participant. Depending on the seriousness of the infraction the penalty for such actions can range from a deduction of up to fifty percent (50%) of the team's points to expulsion of the entire team. Penalties of this type will only be imposed after a complete review of the incident by the organizers.

G.7.2.1.1 Prohibited Material

Alcoholic beverages, firearms, weapons of any type, and illegal materials are prohibited at BAJA SAEINDIA® sites. The penalty for violation of this rule is the immediate expulsion of the entire team, not just the individual(s) involved. This rule applies to team members, advisors, and any individuals working with the team on-site.

G.7.2.1.2 Tobacco Products and Electronic Cigarettes

The use of all tobacco products or using e-cigarettes on-site is prohibited.

G.7.1.2.3 Footwear

All individuals on-site shall wear durable and sturdy closed-toe shoes. Open-toed shoes, slippers, chappals, etc. are explicitly prohibited.

G.7.1.2.4 Parties

Disruptive parties either on or off-site must be prevented by the faculty advisor or team captain.

G.7.1.2.5 Housekeeping

Clean-up of trash and debris is the responsibility of the teams. Please make an effort to keep the paddock area clean and uncluttered. At the close of the day, each team must clean their work area.

G.7.1.2.6 Site Condition

Please help the organizers keep the site clean. The sites used for BAJA SAEINDIA® are generally private property and should be treated as such. Competitors are reminded that they are guests. All trash should be placed in the receptacles provided. Glass is not allowed on the grounds. Failure to clean the premises will result in an unsportsmanlike conduct penalty. Competitors are encouraged to clean their areas after meals.

G.7.1.2.7 Personal Transportation

The use of motorcycles, quads, bicycles, scooters, skateboards, rollerblades, or similar person-carrying or motor-driven devices by team members and spectators in any part of the competition area, including the paddocks is prohibited.

G.7.2.2 Spectator Rules

G.7.2.2.1 General

The organizers typically do not have a direct line of communication with spectators other than on the spot at the competition; thus, the competitors, faculty, and volunteers are expected to help inform the spectators of the safety rules and help restrict spectators to the spectator areas.

G.7.2.2.2 Alcoholic Beverages

Spectators may not drink or possess alcoholic beverages at any competition location.

G.7.2.2.3 Access Restriction

Spectators must keep back a specified distance from the event areas as decided by the organizers and from any area where vehicles are operating under power. Motor vehicle competitions are potentially dangerous and safety rules will be strictly enforced.

G.7.2.2.4 Children

A competition site is not a safe place for children and unsupervised young people. Spectators who fail to strictly control their children will be asked to leave the site.

G.7.2.2.5 Expulsion

The course officials and organizers have the absolute right to restrict spectator access to any parts of the site and to eject anyone who violates safety rules or ignores the instructions of officials.

G.7.2.2.6 Unsafe Conduct

All participants are required to exercise safe practices and avoid unsafe activities at all times during the competition. The event organizers have the discretionary authority to impose a just penalty for any conduct deemed unsafe. All team members will be held to this rule.

G.7.3 Paddock Rules

G.7.3.1 Refueling

Refueling is not permitted in the paddock/ pit. Before refueling, the vehicle must be stopped, the engine shut off, and the driver completely out of the vehicle. The driver may not be tethered in any way, by a harness, communications equipment, or clothing.

Before refueling, a team's pit crew member must have a fire extinguisher ready and pointed at the fuel transfer point on the vehicle. The exiting driver is the only team member permitted to remove the fuel tank cap.

A team refueling their vehicle before the driver is clear of the vehicle or who fails to have a fire extinguisher present and pointed at the fuel transfer point will be penalized. For infractions occurring before the endurance race, the penalty will be assessed during the endurance race.

G.7.3.2 Speed Limit

When a vehicle is driven anywhere except within the practice area or on event courses it must move at walking speed with a team member walking alongside at a normal pace. During the performance events when the excitement is high, it is particularly important that vehicles move at a walking pace in the paddocks. The walking speed rule will be strictly enforced, and discretionary point penalties will be assessed for violations.

G.7.3.3 Escort Required

When a vehicle is driven anywhere except within the practice area or on event courses, it must have a team member escort the vehicle. The escort shall walk with the vehicle on the right side (to stay close to the firewall

kill switch) and shall remain in the view of the driver at all times. The escort should act as a spotter to the driver, paying special attention to the vehicle's blind spots and other vehicles.

Under no circumstances may anyone other than the driver, ride in or on a vehicle.

Escorts shall remain clear and not touch the vehicle when it is in motion and remain within line of sight to the driver.

G.7.3.4 Team Pit area

The team's pit area should be kept uncluttered at all times. When a team leaves their area, it must be left clean.

G.7.3.5 Team Vehicles

Only the BAJA SAEINDIA® vehicles themselves are allowed in the paddocks. Teams' support trucks and trailers must be parked outside the competition site in a specially designated area.

G.7.3.6 Access Restriction

The organizers may limit the paddocks to team members, faculty advisors, and competition officials.

G.7.3.7 Compressed Gases

Teams shall safely store compressed gas cylinders. Cylinders shall be upright and properly secured by a chain or another method, capped when not in use, and stored such that cylinder temperature is below 52 deg. C (125 deg F).

G.7.3.8 Driving Restrictions

G.7.3.8.1 Off-Site Operation

During the competition, BAJA SAEINDIA® vehicles may only be driven between the paddocks and an event site, during official practice, or in the events themselves, and only after the vehicle has passed technical inspection.

Driving off-site is explicitly prohibited. Teams found to have driven their vehicle at an off-site location during the event may be expelled from the competition.

G.7.3.8.2 Driver Equipment

Drivers not wearing the proper equipment will not be permitted to drive and may have their competition driver's privileges revoked.

G.7.4 Meetings

All team members identified as captains or drivers and all faculty advisors MUST attend all meetings as designated; Attendance at meetings is mandatory. Failure to attend meetings can result in disqualification of members or the entire team.

G.7.5 Tie Breakers

G.7.5.1 Non-Endurance Events

Ties for non-endurance dynamic events will be broken by comparing the score of the second-best time or distance for the event in question. If the tie remains, the tie stands.

G.7.5.2 Endurance Event

Ties in the endurance race will be judged by the endurance event judge and may remain a tie.

G.7.5.3 Overall Event

Ties for the overall winner will be broken in the following order:

1. Endurance Score
2. Total Dynamic Events Score
3. Total Static Events Score

If a tie remains after the prescribed tiebreakers, the tie stands for the overall winners.

G.7.6 Pre-Inspection Operation

Vehicles may not be started or driven before passing technical inspection, except as required as part of the inspection process itself.

G.7.7 Inspection

Any vehicle may be impounded and inspected anytime during the competition. Any vehicle found to have altered or substituted its parts or equipment since passing technical inspection or an engine in violation of the rules may receive a point deduction of 75 points each time it is found in violation.

G.7.8 Surrender of Engine

The organizers and SAEINDIA may recall the engine from any vehicle in the competition in exchange for a new Briggs and Stratton engine. Recalled engines will not be returned and will be inspected at Briggs and Stratton's facilities to confirm compliance with the rules.

G.7.9 Signals and Signage

BAJA SAEINDIA® competitions may use some or all of the signals and signage presented in this section.

G.7.9.1 Endurance - Command Flags

Command flags are just that - flags that the competitor must immediately obey without question.

G.7.9.1.1 Green Flag -

1. When displayed at a starting line or when re-entering the course: The event has started; enter the course under the direction of the starter.
2. When running on the course: The course is clear, proceed.



G.7.9.1.2 Yellow Flag –

When displayed, there is a dangerous situation on the track beyond the flag station. Reduce speed and be prepared to take evasive action or stop on the track. Passing is not permitted unless directed by the course workers.



G.7.9.1.3 Red Flag –

When displayed, there is a dangerous situation somewhere on the track requiring a full-course stop. Come to an immediate, safe, and controlled stop on the course. Passing is not permitted. Pull to the side of the track as much as possible to keep the course open. Follow course worker directions.



G.7.9.1.4 Black Flag (Furled and Pointed) –

Warning, the officials are watching this vehicle's driving - obey the event rules.

G.7.9.1.5 Flag (Displayed) –

1. Pull into the penalty box for a discussion with the Technical Inspector or other official concerning an incident. A penalty may be assessed for the incident.
2. Pull into the penalty box for a mechanical inspection of the car; a dangerous condition has been observed on the vehicle.

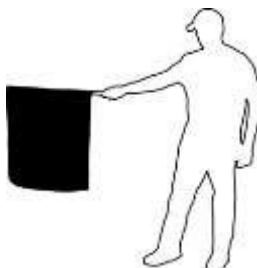

G.7.9.1.6 Chequered Flag –

The event has been completed. Exit the course as directed by event officials.

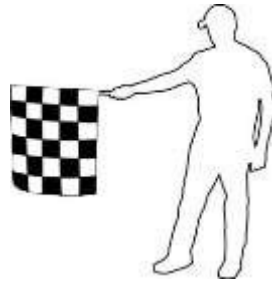

G.7.9.1.7 Arrow –

Orange triangle with a 1.5:1 height to base ratio, with or without a forked base. White or black trim is optional. The minimum base width is 6 inches.

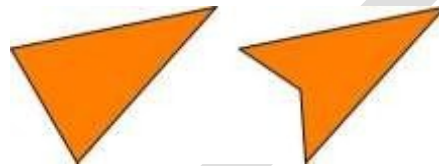

G.7.9.1.8 Control Zone Boundary –

A

This sign denotes the beginning of the control zone around an event. Beyond this sign, the vehicle and driver must be ready to run the event. The driver must have all required equipment on, and the vehicle may not have any adjustments made. Beyond this sign, one team member is allowed to accompany the vehicle. Teams entering the control zone not ready to run or with more than one attendant may be sent to the back of the line.



B

This sign denotes the location of the time control marshal. The time control marshal will position your vehicle to start the event. At this location, a Technical Inspector may do a final compliance check on your vehicle.



G.7.9.1.9 Start Line –

This sign denotes the location of the event starting line. At this location, the driver will be given the signal from the start marshal to begin the run.



G.7.9.1.10 Finish Line –

This sign denotes the end of the run, where a time or distance will be taken. Proceed through the finish line to record your score.



G.7.9.1.11 Stop Line –

All vehicles are required to stop at the stop line at the end of the run. At this location, proceed only upon the instruction of the Finish Marshal.



G.7.9.1.12 End Control Zone –

This sign denotes the end of the control zone boundary.



G.7.9.1.13 Begin Fuel Zone –

This sign indicates the beginning of the fuel zone where fueling is permitted.



G.7.9.1.14 End Fuel Zone –

This sign denotes the end of the fuel zone. Beyond this sign, fueling is not permitted unless approved by the Fuel Zone Official.



G.7.9.1.15 Begin Service –

This sign denotes the beginning of the service area (paddocks and/or hot pit). Beyond this sign, vehicle adjustments, service, and/or maintenance are permitted.



G.7.9.1.16 End Service –

This sign denotes the end of the service area (paddocks and/or hot pit). Beyond this sign, vehicle adjustments, service, and/or maintenance are not permitted.



PART H: APPENDICES

ARTICLE H.1: OVERALL EVENT SCORING SUMMARY

**BAJA SAEINDIA 2026
 hBAJA Overall Scoring Pattern**

Event		Description	Points	Total Points
Virtual Round		Presentation	40	50
		Online Quiz	10	
Physical Round	Static Events	Design Evaluation	100	325
		Cost Evaluation	50	
		Sales Evaluation	50	
		Manufacturing Excellence	50	
		Sustainability Event	25	
		Validation	50	
		CAE Evaluation	NA	
		Innovation Event	NA	
	Dynamic Events	Acceleration	50	275
		Traction Event	50	
		Maneuverability	75	
		Efficiency Event	100	
			Endurance Performance	400
Grand Total			1050	

Any change in scoring pattern shall be informed to the teams through BAJA SAEINDIA Forum.

ARTICLE H.2: SAE TECHNICAL STANDARDS

The SAE Technical Standards Board (TSB) has made the following SAE Technical Standards available online, at no cost, for use by Collegiate Design teams. Standards are important in all areas of engineering, and we urge you to review these documents and become familiar with their contents and use.

The technical documents listed below include both (1) standards that are identified in the rules and (2) standards that the TSB and the various rules committees believe are valuable references or which may be mentioned in future rule sets.

All Collegiate Design Series teams registered for competitions in SAEINDIA have access to all the standards listed below - including standards not specific to your competition.

SAE Technical Standards included in the CDS Rules

BAJA SAE

J586 - Stop Lamps for Use on Motor Vehicles Less Than 2032 mm in Overall Width

J759 - Lighting Identification Code

J994 - Alarm - Backup - Electric Laboratory Tests

J1741 - Discriminating Back-Up Alarm Standard

AIS-024 (Rev.1) Part A

AIS-028 (Version 3)

Formula Hybrid

J1318 - Gaseous Discharge Warning Lamp for Authorized Emergency, Maintenance and Service Vehicles

J1673 - High Voltage Automotive Wiring Assembly Design

Formula SAE

SAE 4130 steel is referenced but no specific standard is identified

SAE Grade 5 bolts are required but no specific standard is identified

Super-mileage

J586 - Stop Lamps for Use on Motor Vehicles Less Than 2032 mm in Overall Width

SAE Technical Standards for Supplemental Use

Standards Relevant to BAJA SAE

J98 - Personal Protection for General Purpose Industrial Machines. Standard

J183 - Engine Oil Performance and Engine Service Classification - Standard

J306 - Automotive Gear Lubricant Viscosity Classification - Standard

J429 - Mechanical and Material Requirements for Externally Threaded Fasteners - Standard

J512 - Automotive Tube Fittings - Standard

J517 - Hydraulic Hose - Standard

J1166 - Sound Measurement - Off-Road Self-Propelled Work Machines Operator-Work Cycle

J1194 - Rollover Protective Structures (ROPS) for Wheeled Agricultural Tractors

J1362 - Graphical Symbols for Operator Controls and Displays on Off-Road Self-Propelled Work Machines - Standard

J1614 - Wiring Distribution Systems for Construction, Agricultural and Off-Road Work Machines

J1703 - Motor Vehicle Brake Fluid - Standard

J2030 - Heavy Duty Electrical Connector Performance Standard

J2402 - Road Vehicles - Symbols for Controls, Indicators and Tell-Tales - Standard

Standards Relevant to Formula SAE

J183 - Engine Oil Performance and Engine Service Classification - Standard

J306 - Automotive Gear Lubricant Viscosity Classification - Standard

J429 - Mechanical and Material Requirements for Externally Threaded Fasteners - Standard

J452 - General Information - Chemical Compositions, Mechanical and Physical Properties of SAE Aluminium Casting Alloys - Information Report

J512 - Automotive Tube Fittings - Standard

J517 - Hydraulic Hose - Standard

J637 - Automotive V-Belt Drives - Recommended Practice

J829 - Fuel Tank Filler Cap and Cap Retainer

J1153 - Hydraulic Cylinders for Motor Vehicle Brakes - Test Procedure

J1154 - Hydraulic Master Cylinders for Motor Vehicle Brakes - Performance Requirements - Standard

J1703 - Motor Vehicle Brake Fluid - Standard

J2045 - Performance Requirements for Fuel System Tubing Assemblies - Standard

J2053 - Brake Master Cylinder Plastic Reservoir Assembly for Road Vehicles – Standard

ARTICLE H.3: OFFICIAL SOCIAL MEDIA HANDLES

Following are the official social media handles of BAJA SAEINDIA®:

[BAJA SAEINDIA \(@bajasaeindia\) • Instagram photos and videos](#)

[BAJA SAE India - Home | Facebook](#)

[BAJA SAEINDIA \(@BAJASAEINDIA\) / Twitter](#)

[BAJA SAEINDIA: Overview | LinkedIn](#)

ARTICLE H.4: LIST OF ABBREVIATIONS

AED	Automatic External Defibrillator	LED	Light Emitting Diode
AN/MS	Army/Navy Military Standard	MB	Megabyte
CDS	Collegiate Design Series	OEM	Original Equipment Manufacturer
CPR	Cardiopulmonary Resuscitation	PDF	Portable Document Format by Adobe
CV	Constant Velocity	RF	Radio Frequency
CVT	Continuously Variable Transmission	RPM	Revolutions per minute
DF	Design Finals	SAE	Society of Automotive Engineers
DQ	Disqualified	SFI	SEMA Foundation Inc.
FA	Fuel Area	XLS	Excel Spreadsheet by Microsoft
FEA	Finite Element Analysis	FZ	Fuel Zone
FQ	Fuel Quarantine	ID	Inside Diameter
HV	High Voltage	MCU	Motor Controller Unit
LV	Low Voltage	EV	Electric Vehicle/s
VAC	Alternating Voltage	MCB	Miniature Circuit Breaker
RMS	Root mean square	AIS	Automotive Industry Standards
VDC	Direct Voltage	UL	Underwriters Laboratories
DC	Direct Current	LED	Light Emitting Diode
GLV	Grounded Low Voltage	FAR	Federal Acquisition Regulation
TSAL	Tractive System Active Light	ESS	Electrical Safety Sheet
RTDS	Ready To Drive Sound	F-N-R	Front-Neutral-Rear
BMS	Battery Management System	ASTM	American Society for Testing and Materials
AIR	Accumulator Isolation Relay	EN	European Standards
HVIL	High Voltage Inter-Lock	TS	Tractive System
SoC	State of Charge	Ms	millisecond
DOT	Department of Transportation	PPE	Personal Protective Equipment/s
ISO	International Organization for Standardization	IEC	International Electro-technical Commission
SA	Swappable Area		